

ENERGY SAVINGS FROM AIR SEALING LARGE BUILDINGS

Energy Design Conference & Expo, Duluth, MN

Dave Bohac P.E.

Director of Research



Continuing Education Credit Information

- In accordance with the Department of Labor and Industry's statute 326.0981, Subd. 11,

“This educational offering is recognized by the Minnesota Department of Labor and Industry as satisfying **1.5 hours** of credit toward **Building Officials and Residential Contractors** continuing education requirements.”

For additional continuing education approvals, please see your credit tracking card.

Acknowledgements

This project was supported in part by a grant from the Minnesota Department of Commerce, Division of Energy Resources through a Conservation Applied Research and Development (CARD) program



What we do

- Program Design and Delivery
- Lending Center
- Engineering Services
- Innovation Exchange
 - Research
 - Education and Outreach
- Public Policy



[Who We Are >](#)

[What We Do >](#)

[Who We Work With >](#)

[Our Impact >](#)

[Innovation Exchange >](#)

[Find Financing & Incentives >](#)

Updated Online Resource Center

Browse the Innovation Exchange's library of energy tools for technical reports, info visualizations, animations, and more!

[Learn More >](#)



Technical Reports



Videos



Webinars



Presentations



Data & Reference



Info Visualization

From The Blog

[See All Posts](#)

Electric Thermal Storage vs. Heat Pump Water Heaters

Which residential water heating technology is best for meeting electricity energy saving goals? It will depend if the goal is reducing total consumption or lowering peak demand.

[Read More](#)



News

[See All News](#)

CEE Housing Solutions Home Sells

November 4, 2013 This past Friday, November 1st, the CEE Housing Solutions home in Richfield sold.

[Read More](#)



CEE Staff Member Presents on Energy Audits and Retro-Commissioning Webinar

October 28, 2013 Chris is presenting on the outcomes and benefits of PBEEEP, Minnesota's Public Building Retro-Commissioning Program.

[Read More](#)



Featured Staff

[See All Staff](#)



Mark Hancock, P.E.
Senior Mechanical Engineer

[Full Bio](#)



Brenda Yaritz
Senior Loan Officer

[Full Bio](#)



Project Team

- Center for Energy and Environment

- Jim Fitzgerald
- Martha Hewett
- Andrew Lutz
- Kirk Kholehma

Air Leakage Test Staff:

CEE - Alex Haynor, Jerry Kimmen,
Joel Lafontaine, Dan May,
Erik Moe, Tom Prebich,
and Isaac Smith

- Air Barrier Solutions

- Larry Harmon

Bruce Stahlberg of Affordable Energy
Solutions

- The Energy Conservatory

- Gary Nelson
- Paul Morin
- Peter Burns

Large Building Tightness Specification

- Measure the air flow rate needed to pressurize & depressurize the building by **75Pa** (0.3 in. wc.)
- Divide by the building envelope area – typically the exterior walls + roof + floor (6 sides)
- Results from 387 US C&I buildings
 - Average = 0.72 cfm/ft²
 - Range 0.03 – 4.3 cfm/ft²

Code Requirements

- US Army Corp Engineers = 0.25 cfm/ft²
 - Tested over 300 buildings
 - Average = 0.16 cfm/ft²
- IECC 2012 (7 states) whole building compliance path = 0.40 cfm/ft²
- Washington State: Buildings over five stories require a whole building test, but do not have to pass a prescribed value.
- City of Seattle : All buildings require a whole building test, but do not have to pass a prescribed value.

Why do we care about building air leakage?

- HVAC systems pressurize buildings to **eliminate** infiltration – don't they?
- When HVAC is off => air infiltration
- Pressurization not always effective or implemented correctly
- NIST/Persily tracer gas results – infiltration can be significant

Air Handler Pressurization

WARM WEATHER - HVAC OFF

Temp out = 68° F
Infiltration = 0 cfm
Exfiltration = 0 cfm

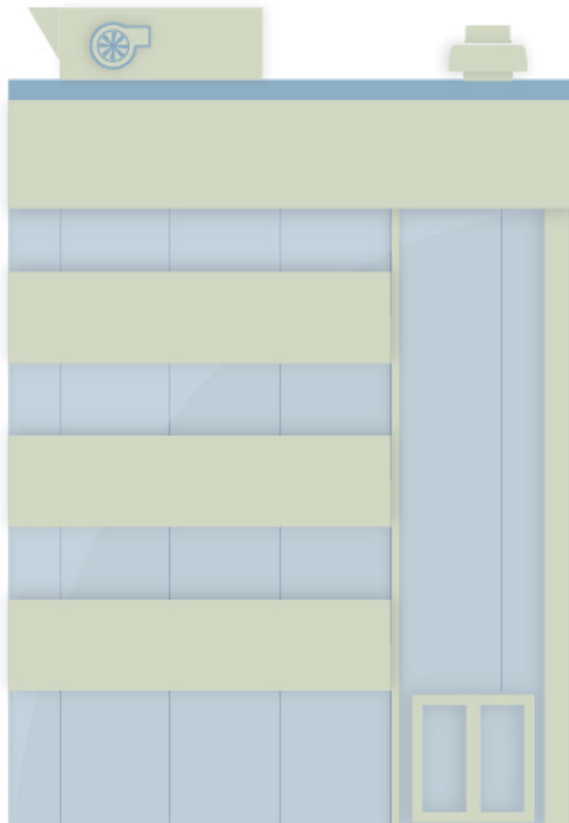

NO WIND

WARM WEATHER - HVAC ON

Temp out = 68° F
Infiltration = 0 cfm
Exfiltration = 8,425 cfm
= 10,500 - 2,075 cfm

Pressure = 0 Pa
0 In wc

10,500 cfm

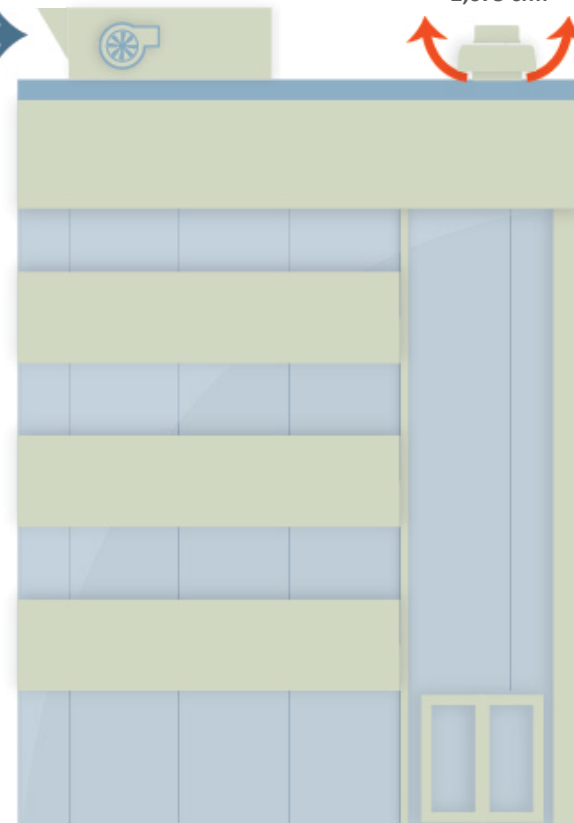

NO WIND

Pressure = 12.5 Pa
0.5 In wc



4 Story 60,000sf Office Building: leakage = 27,000 cfm@75Pa, 0.5 cfm@75/ft²

Roof Top Unit Operation

MINIMUM OUTSIDE AIR (Cooling Mode)

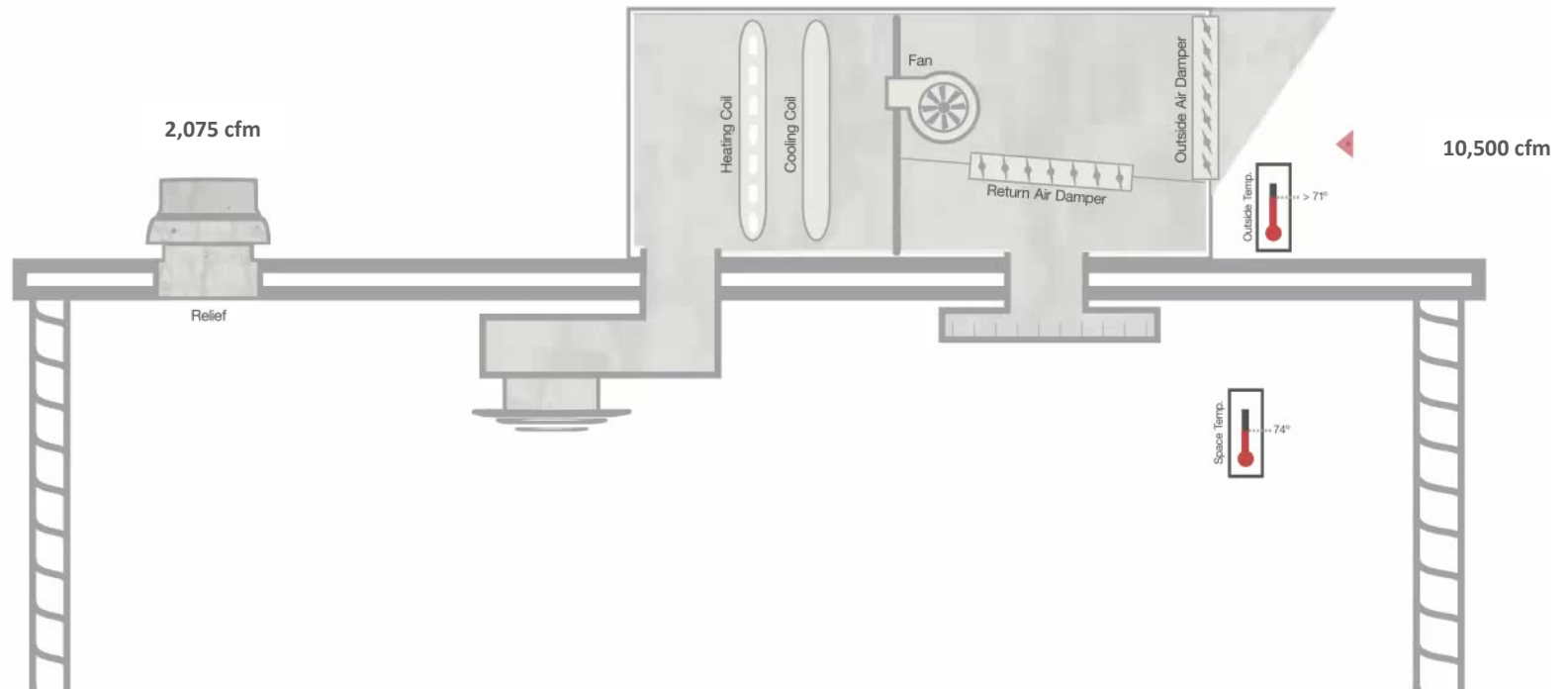

Single-zone Constant Volume AHU

- Supply and Return Fans turn on/off by schedule
- Outside Air Damper has a minimum position setpoint for ventilation
- Relief Damper controls air exhausted from the building

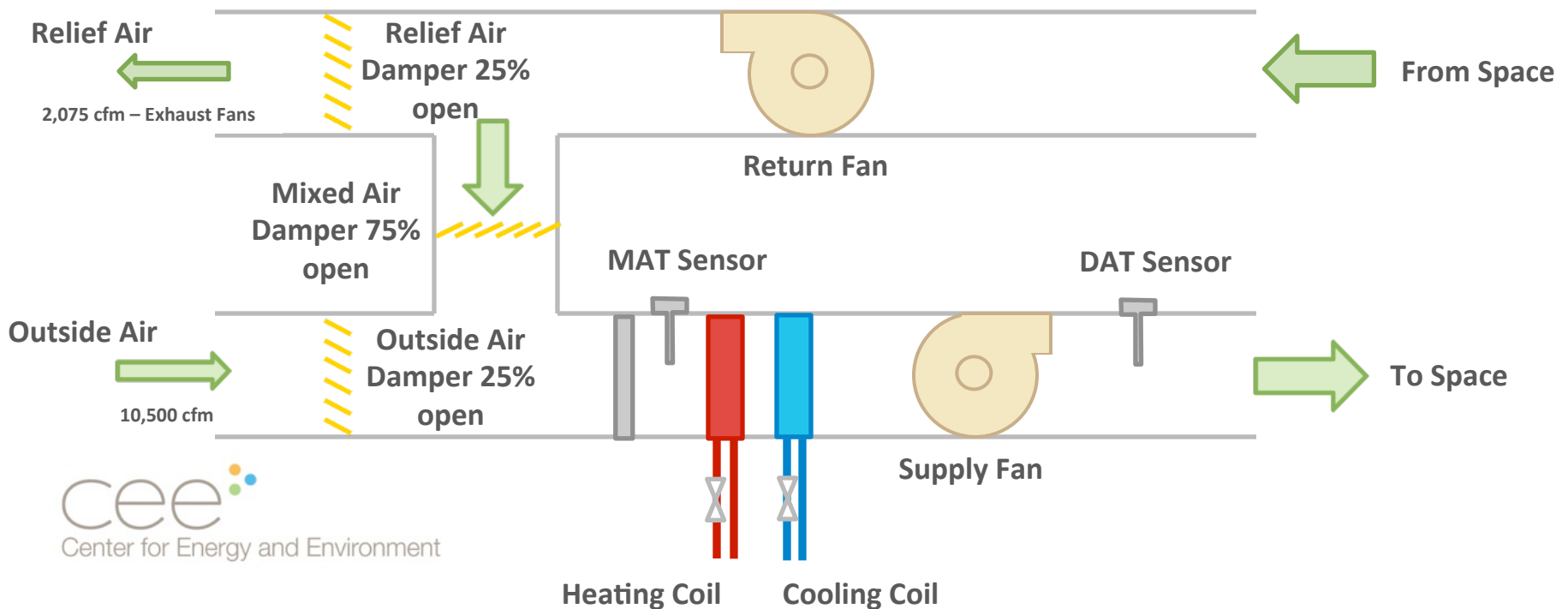

Air Handler Pressurization

COLD WEATHER - HVAC OFF

Temp out = 20° F
Infiltration = 2,350 cfm
Exfiltration = 2,350 cfm

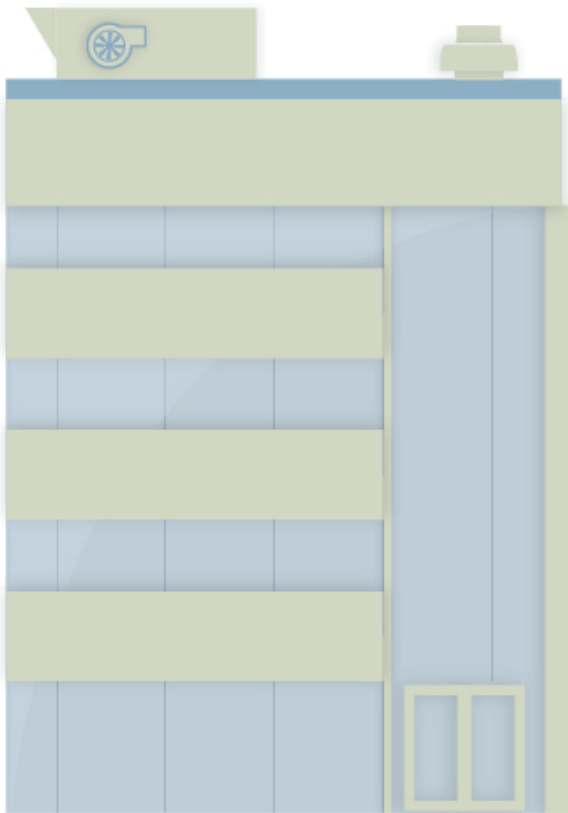

NO WIND

Pressure = 5.0 Pa
0.02 In wc

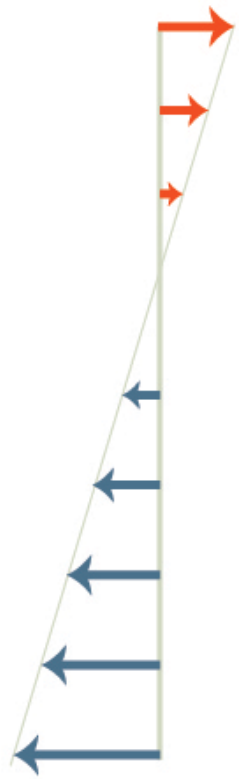

Pressure = 12.4 Pa
0.05 In wc

COLD WEATHER - HVAC ON

Temp out = 20° F
Infiltration = 0 cfm
Exfiltration = 8,425 cfm

10,500 cfm

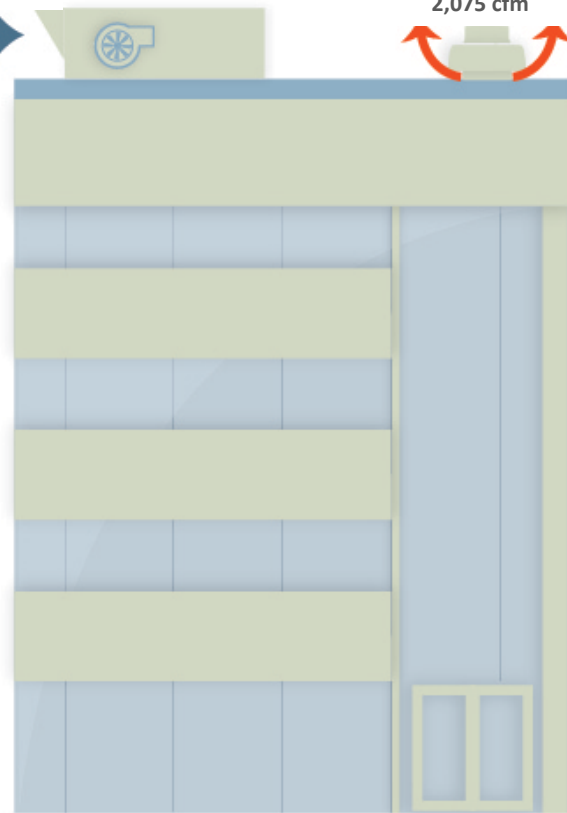

NO WIND

Pressure = 18.4 Pa
0.08 In wc

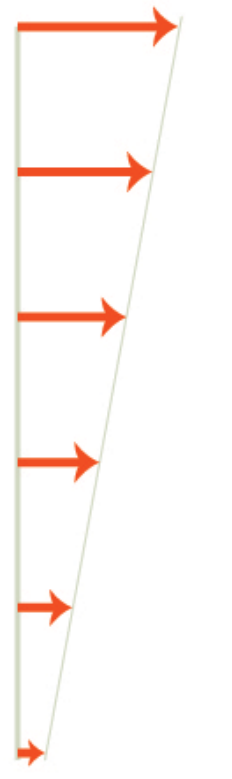

Pressure = 1.0 Pa
0.01 In wc

4 Story 60,000sf Office Building: leakage = 27,000 cfm@75Pa, 0.5 cfm@75/ft²

Air Handler Pressurization

COLD WEATHER - HVAC OFF

Temp out = 20° F
Infiltration = 2,350 cfm
Exfiltration = 2,350 cfm

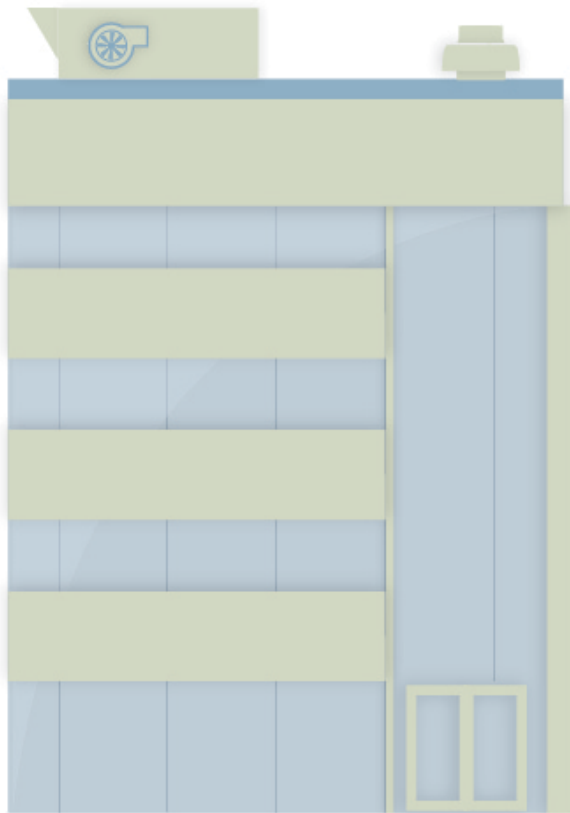

NO WIND

Pressure = 5.0 Pa
0.02 In wc

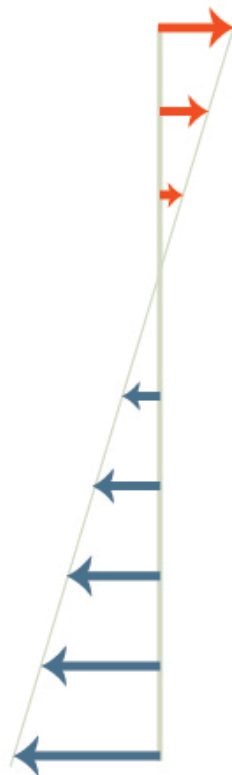

Pressure = 12.4 Pa
0.05 In wc

COLDER WEATHER - HVAC ON

Temp out = 0° F
Infiltration = 292 cfm
Exfiltration = 8,717 cfm

10,500 cfm

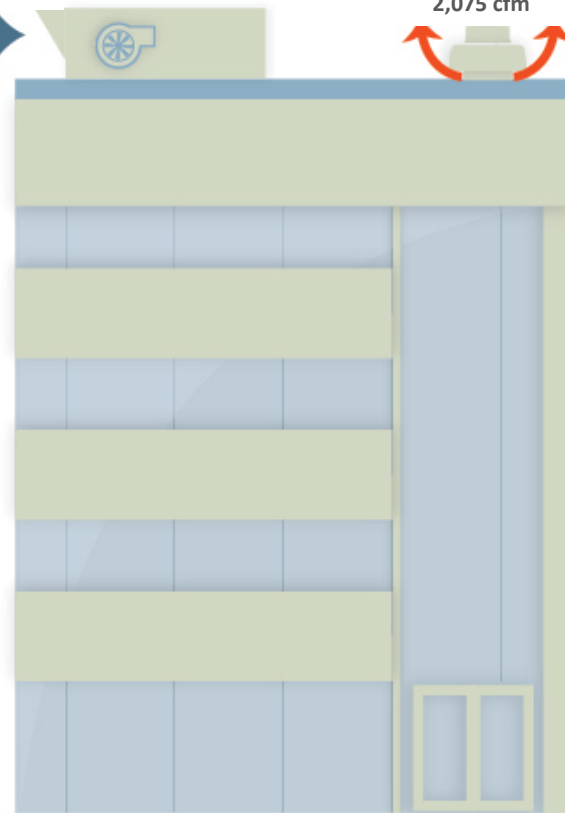

NO WIND

Pressure = 24.7 Pa
0.10 In wc

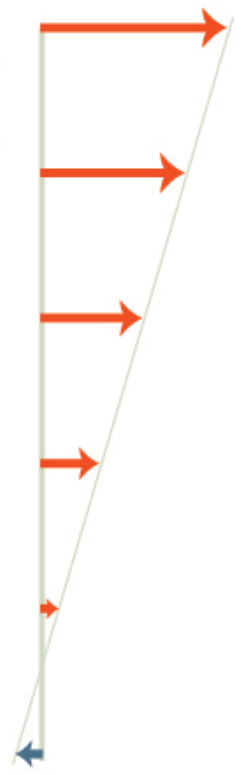

Pressure = -3.6 Pa
-0.01 In wc

4 Story 60,000sf Office Building: leakage = 27,000 cfm@75Pa, 0.5 cfm@75/ft²

Roof Top Unit Operation

MINIMUM OUTSIDE AIR
(Cooling Mode)

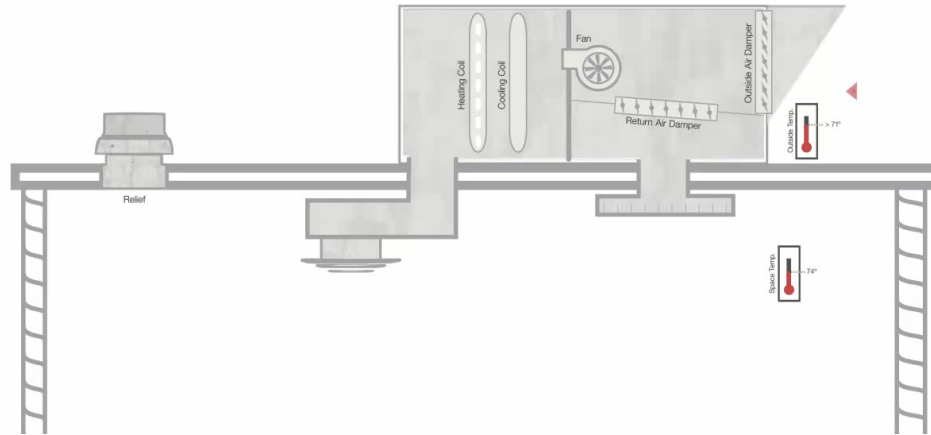

FULLY ECONOMIZED

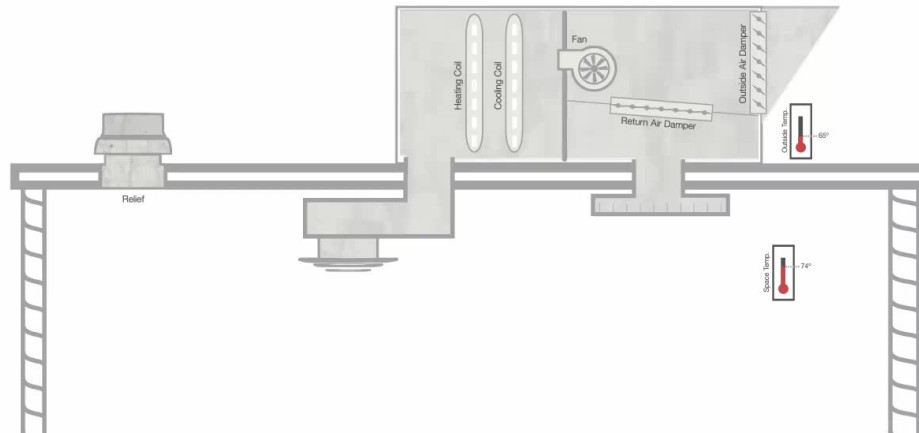

Single-zone Constant Volume AHU

- Economizer operation
 - Mild weather when building needs cooling
 - Open outdoor air dampers, exhaust dampers follow; OA – EA stays the same?

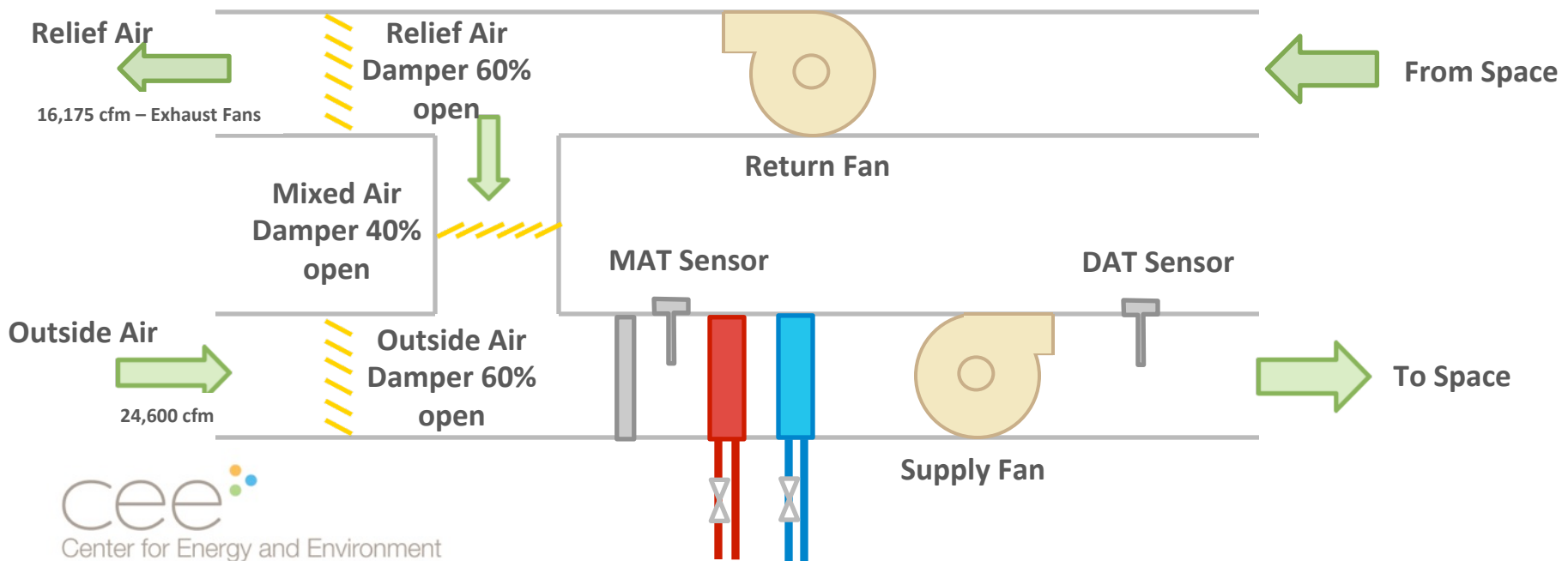

Variable Volume AHU with VAV Boxes

- Supply and Return Fans
 - Supply fan VFD modulates to meet Duct Static Pressure (DSP) Setpoint
 - Return fan lags supply fan to maintain positive pressure

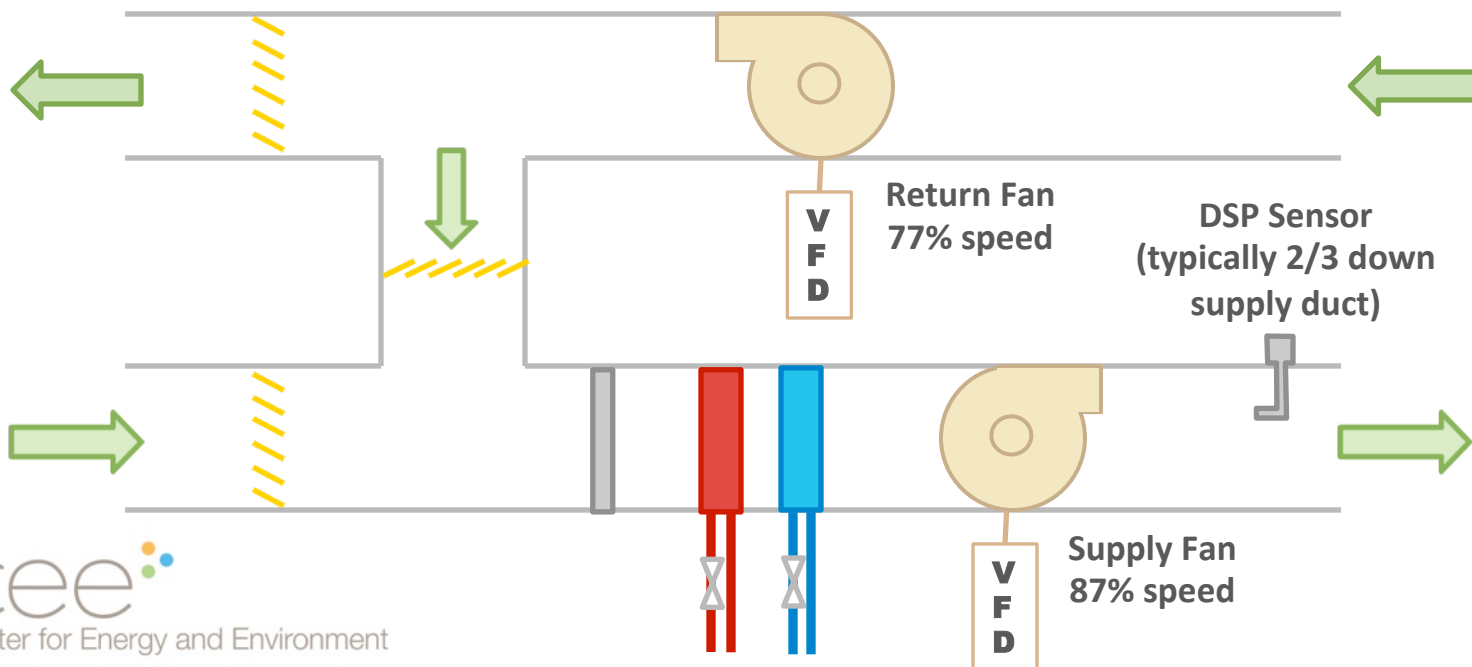

Model Infiltration: Range of Flow Imbalance

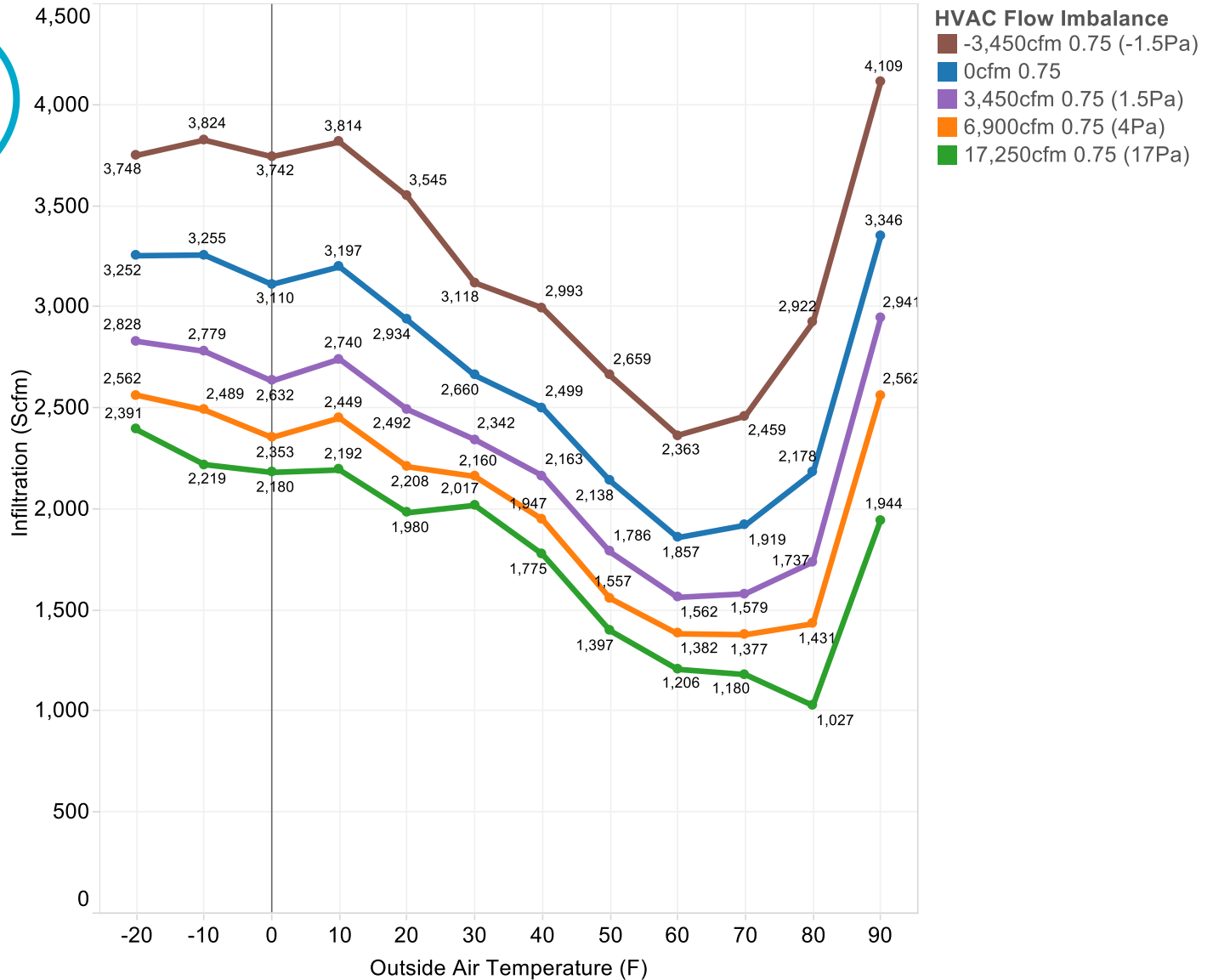

Model Infiltration: Range of Flow Imbalance

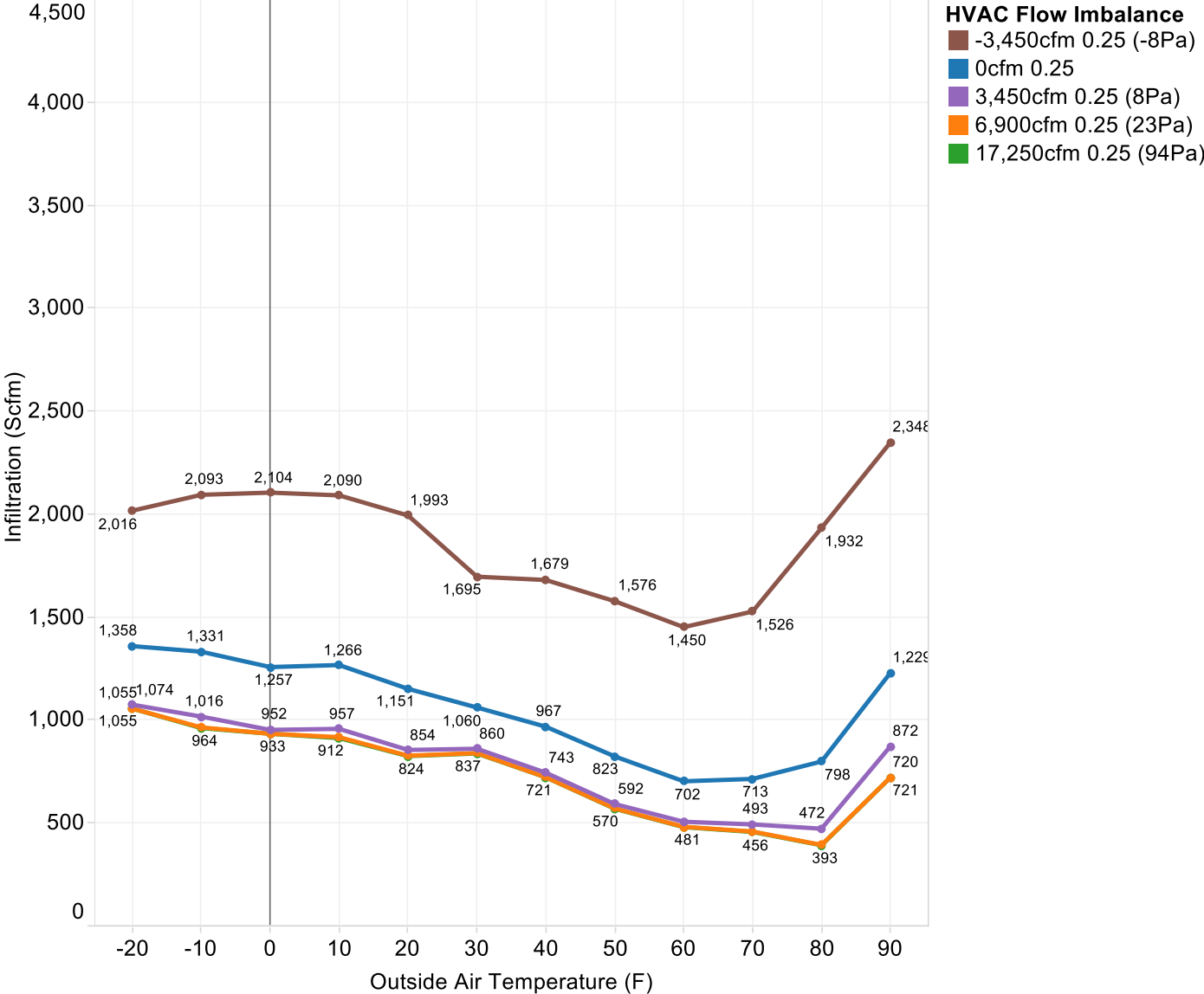

1 Story 60,560ft² Elementary School: leakage = 14,890 cfm@75Pa (0.25cfm@75ft²)

Model Infiltration: Range of Flow Imbalance

Envelope Leakage= 0.75 cfm@75Pa/ft²

	HVAC Flow Imbalance, OA - EA (cfm)				
	-3,450	0	3,450	6,900	17,250
Avg Infil. (cfm)	2,986	2,444	2,077	1,849	1,652
Avg Infil. (ach)	0.25	0.20	0.17	0.15	0.14
Heat Load (therms/yr)	7,264	6,114	5,260	4,732	4,308
% Space Heating	19%	16%	14%	12%	11%
Cost (\$)	\$4,213	\$3,546	\$3,051	\$2,745	\$2,499

Model Infiltration: Range of Flow Imbalance

Envelope Leakage= 0.75 cfm@75Pa/ft²

	HVAC Flow Imbalance, OA - EA (cfm)				
	-3,450	0	3,450	6,900	17,250
Avg Infil. (cfm)	2,986	2,444	2,077	1,849	1,652
Avg Infil. (ach)	0.25	0.20	0.17	0.15	0.14
Heat Load (therms/yr)	7,264	6,114	5,260	4,732	4,308
% Space Heating	19%	16%	14%	12%	11%
Cost (\$)	\$4,213	\$3,546	\$3,051	\$2,745	\$2,499

Envelope Leakage= 0.25 cfm@75Pa/ft²

	HVAC Flow Imbalance, OA - EA (cfm)				
	-3,450	0	3,450	6,900	17,250
Avg Infil. (cfm)	1,725	951	708	678	676
Avg Infil. (ach)	0.14	0.08	0.06	0.06	0.06
Heat Load (therms/yr)	4,004	2,439	1,875	1,813	1,809
% Space Heating	10%	6%	5%	5%	5%
Cost (\$)	\$2,322	\$1,414	\$1,087	\$1,052	\$1,049

What about Energy Recovery Ventilators?

- Why not run the exhaust air through an ERV to recovery some of that energy instead of forcing it out through the envelope?
- Need a tighter envelope to accomplish ERVs with infiltration control

erom secruoser ygrene esu ot srenwo g

se in US office build



Center for Energy
and Environment



The Energy Conservatory

How leaky or tight are US buildings?

- Test results compiled by the National Institute of Standards and Technology (NIST) – Emmerich and Persily – over the past 15 years
- **387** commercial and institutional buildings
- **NOT RANDOM**: researchers, low-energy programs, private testing firms
- Used to model air infiltration energy loads and help establish leakage standards

NIST Results from US whole building tests

		6-sided at 75Pa (cfm/ft ²)			
Dataset	Qty	Mean	Std Dev	Min	Max
Efficiency Vermont	36	0.35	0.38	0.03	1.78
ASHRAE RP 1478	16	0.29	0.20	0.06	0.75
Washington	18	0.40	0.15	0.11	0.64
Other VT/NH	79	0.54	0.40	0.05	1.73
Other	10	0.30	0.23	0.09	0.75
All new data	159	0.36	0.30	0.03	1.78

All previous data	228	0.92	0.70	0.09	4.28
--------------------------	------------	-------------	-------------	-------------	-------------

All Buildings	387	0.72	0.63	0.03	4.28
----------------------	------------	-------------	-------------	-------------	-------------

USACE & Navy	300	0.16		USACE Std = 0.25	
-------------------------	------------	-------------	--	------------------	--

NIST Results: Frequency Histogram

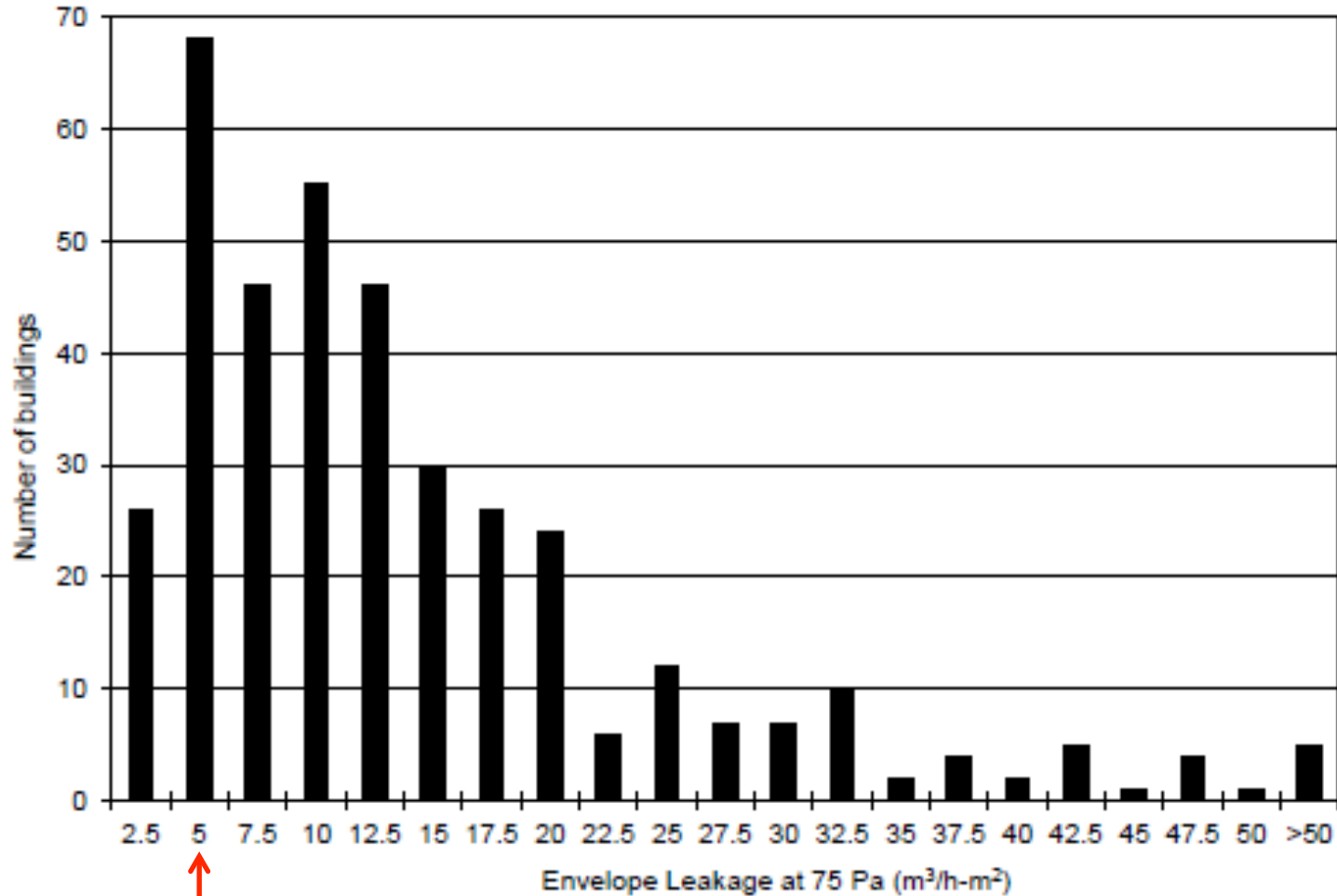

USACE Std = 4.5
20-25% meet Std

Multiply by 0.055 >> cfm/ft²

Emmerich and Persily 2013

NIST Results: Weak Trends

- Tighter – office, education, public assembly & long-term health care
- Leakier – retail, restaurants, industrial
- Leakier exterior walls – frame, masonry/metal, & frame/masonry

NIST Results: Effect of Building Size

Buildings > 54,000ft² twice as tight

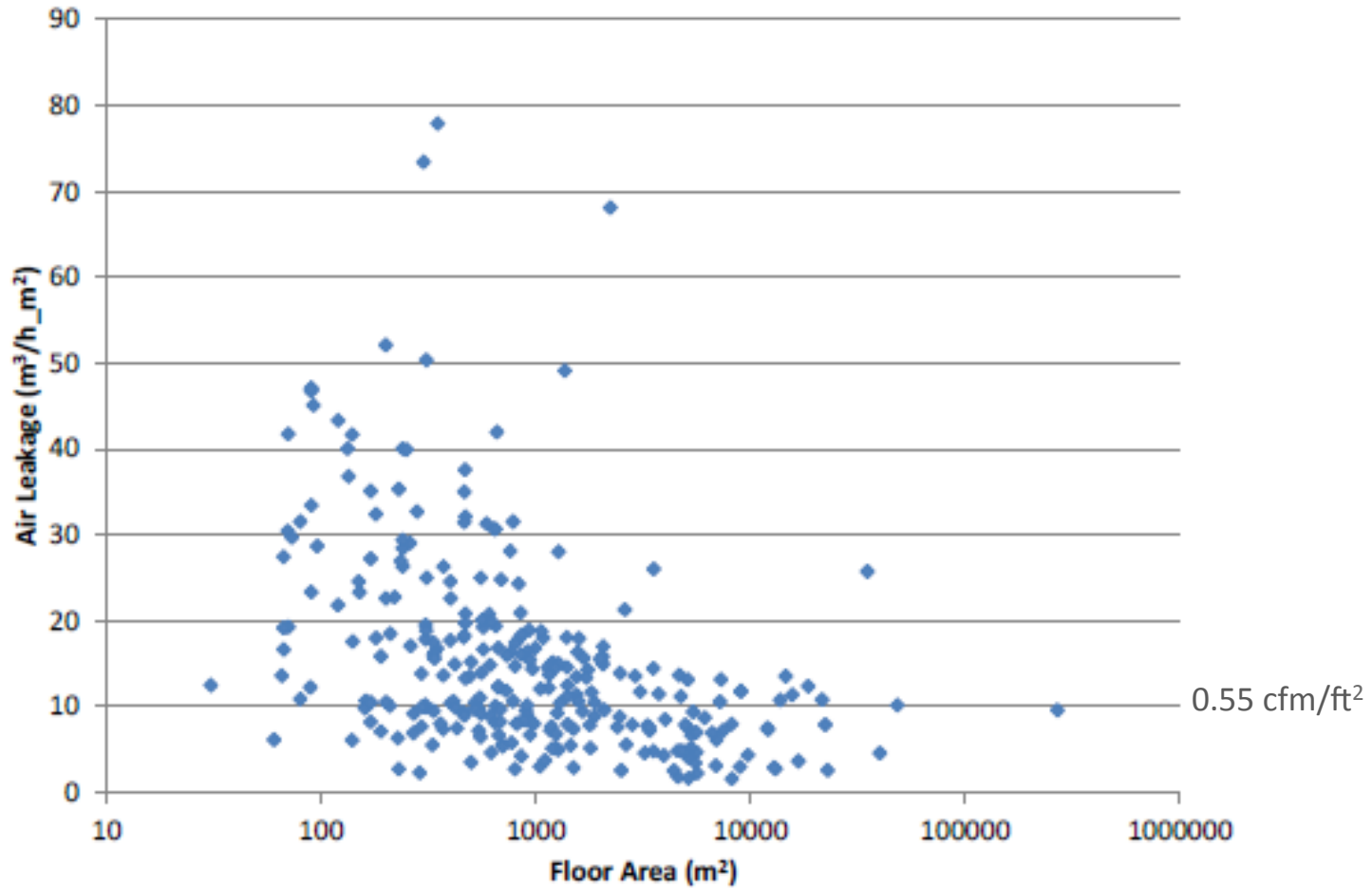

NIST Results: Effect of Climate

Heating degree days > 3,600 one third tighter

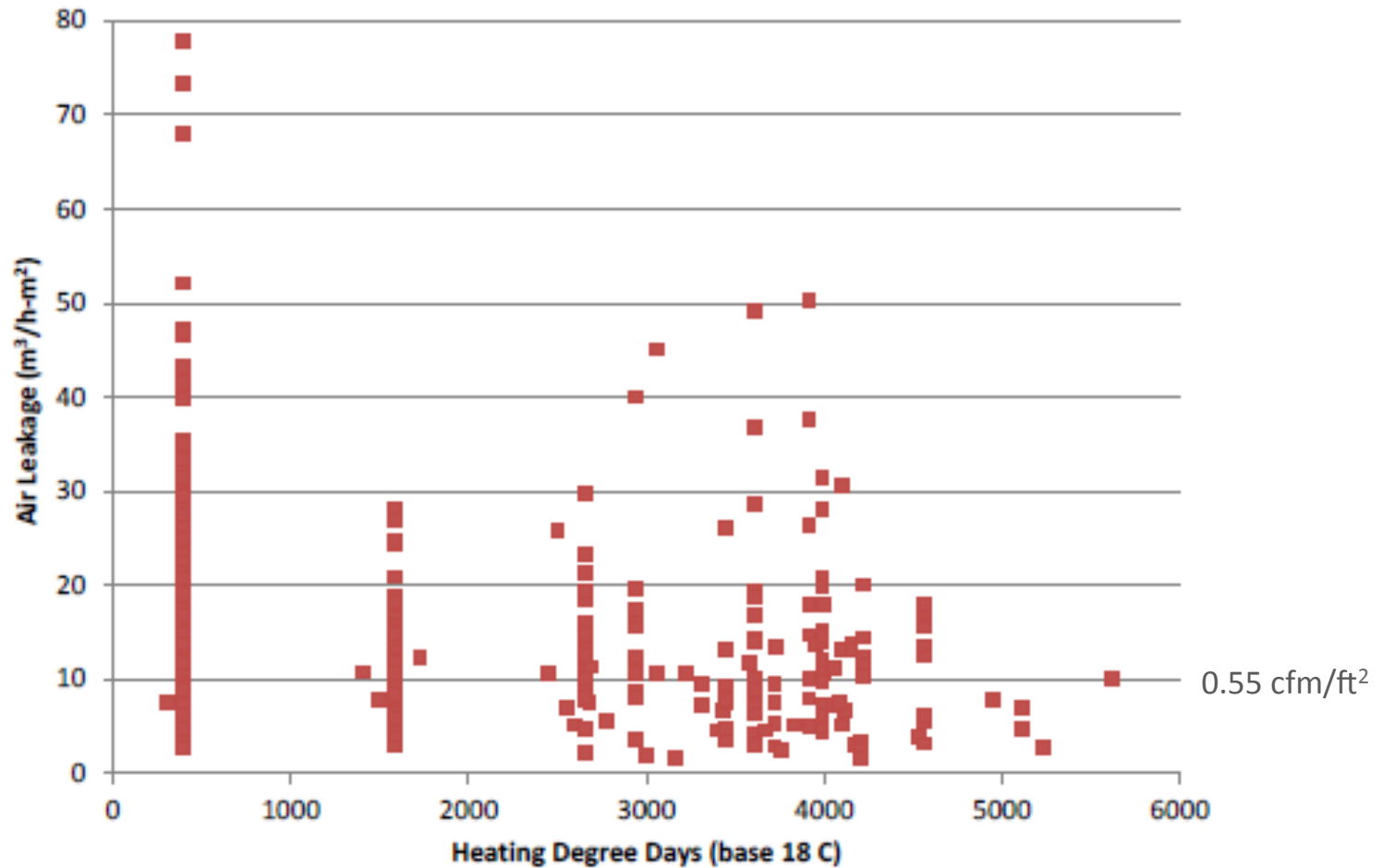

NIST Results: Effect of Age

138 buildings with no air barriers built since 1950 – no strong trend

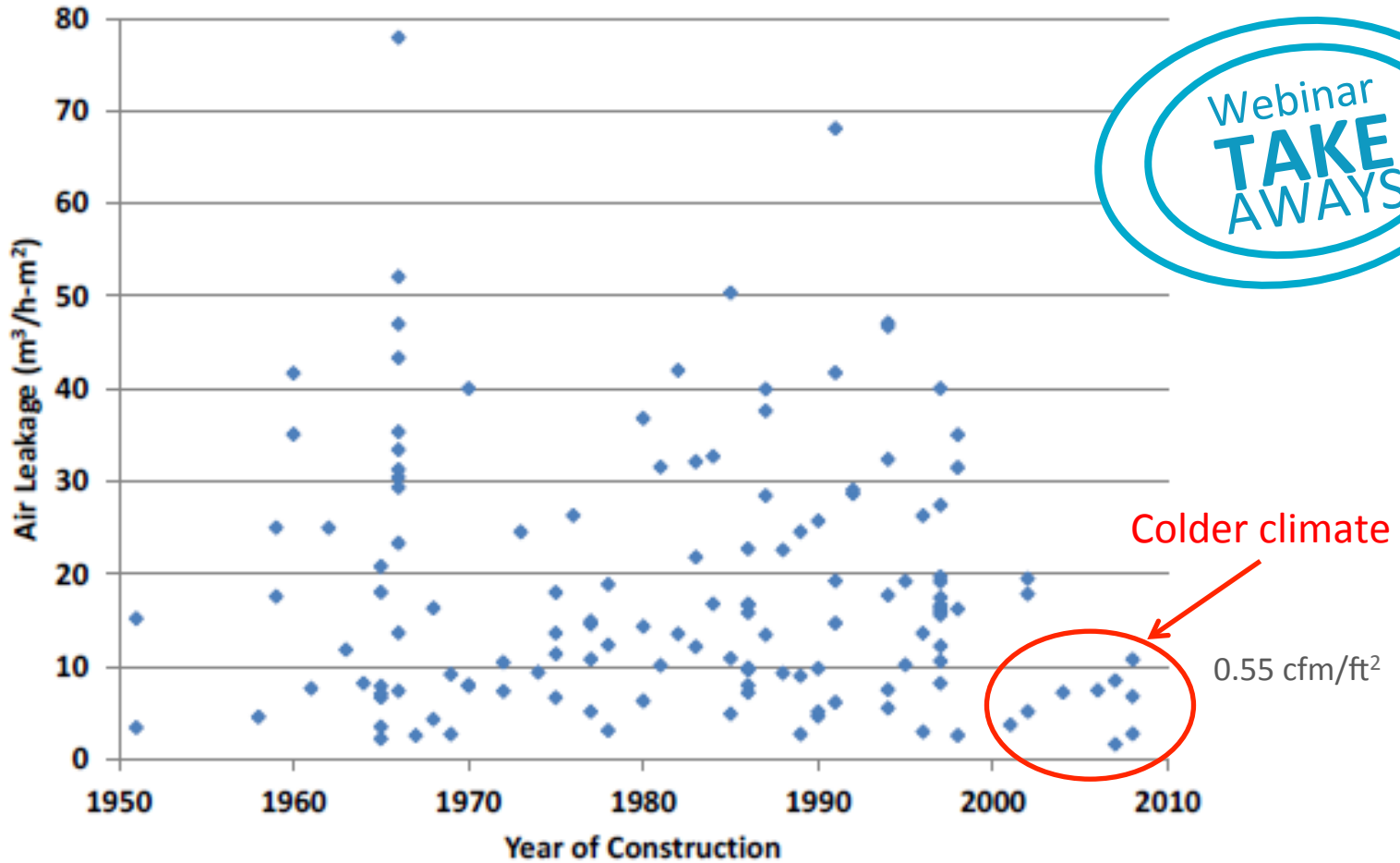

NIST Results: LEED Buildings

- 23 LEED buildings; average = 0.29 cfm/ft²
- Significantly tighter than average of other 364 buildings
- Slightly (5%) leakier than other 56 buildings with an air barrier

NIST Results: Effect of Air Barrier

Buildings with air barrier are 70% tighter

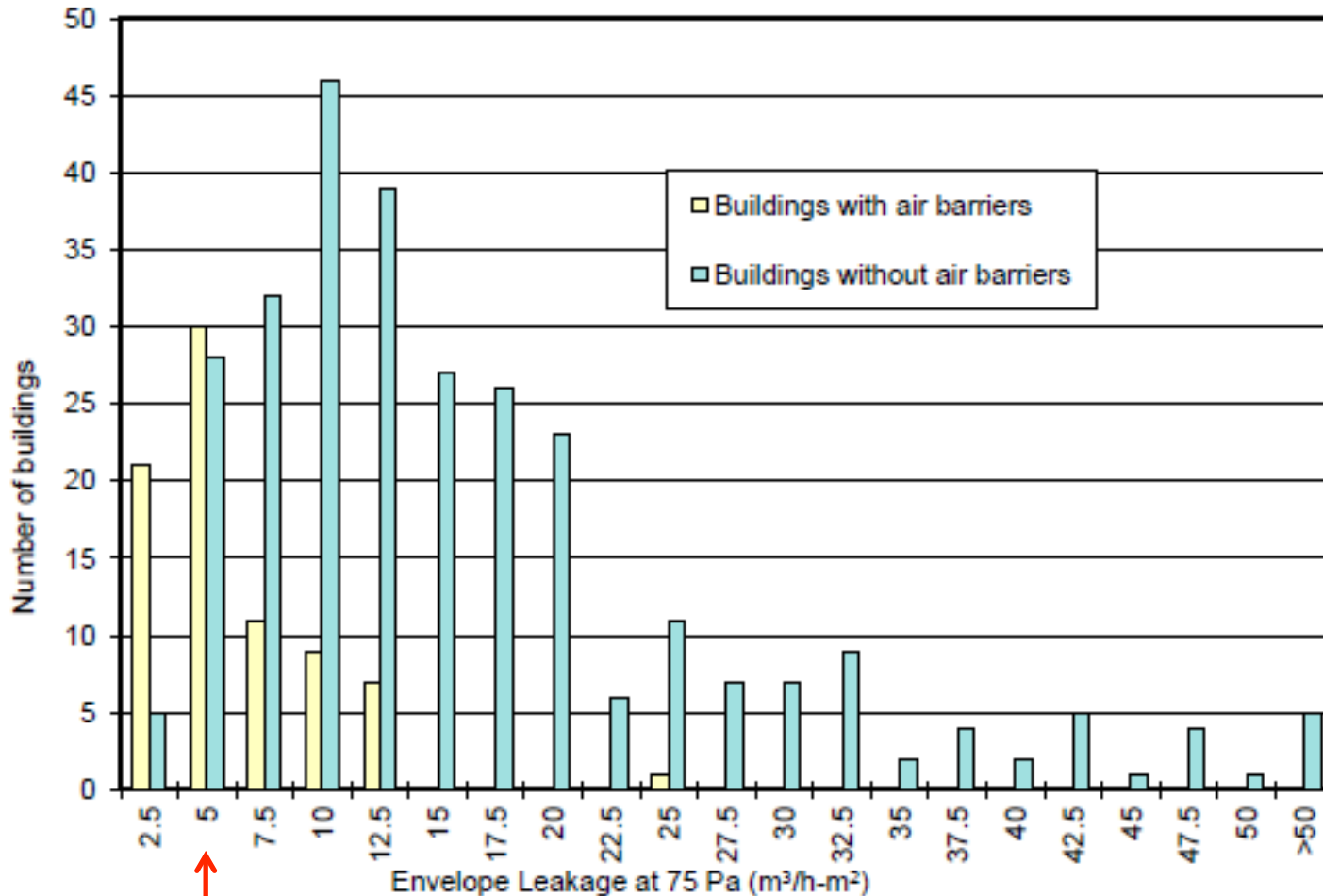

USACE Std = 4.5, 0.25cfm/ft²

NIST Results: Effect of Air Barrier

Compare no air barrier to tight construction

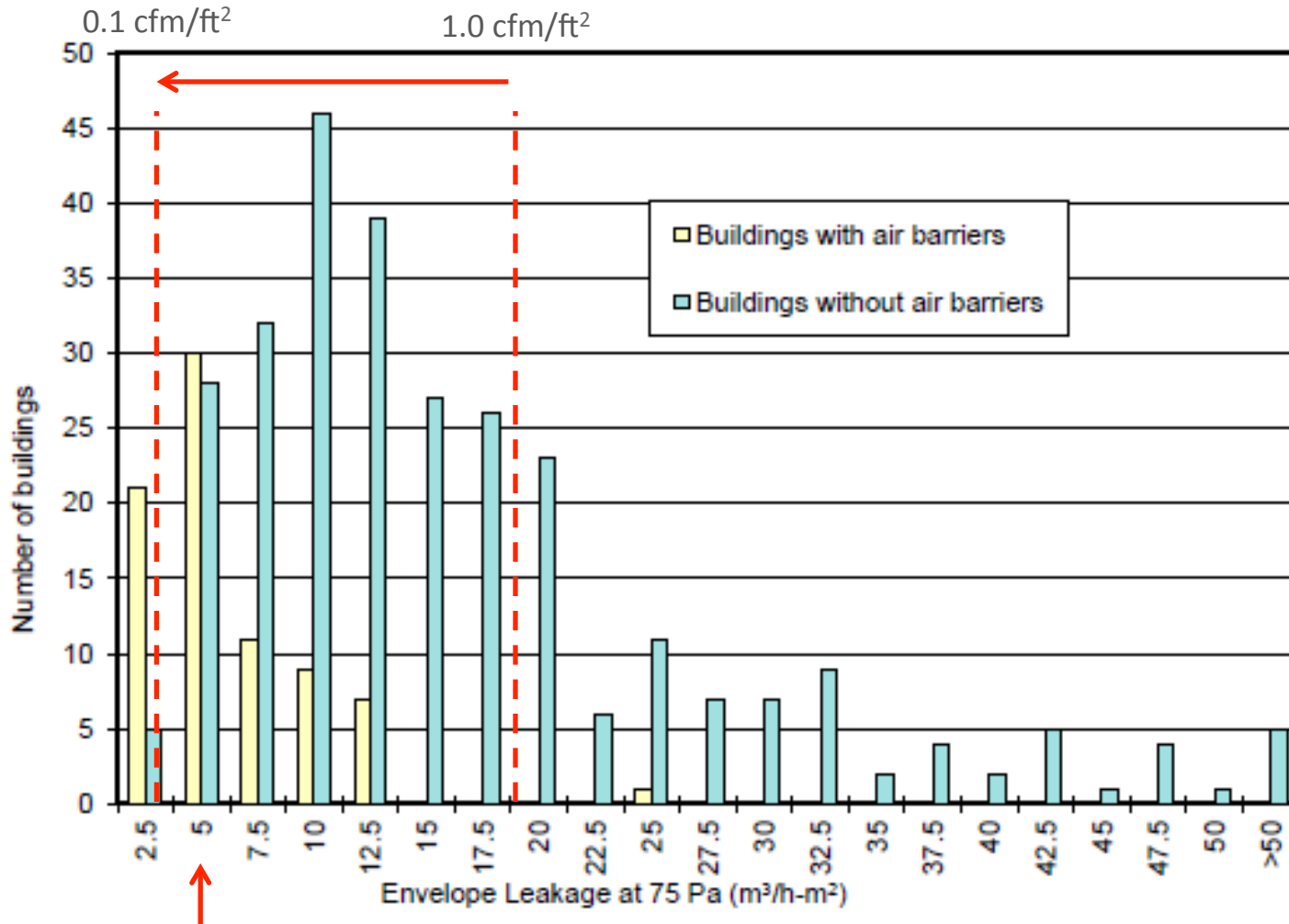

USACE Std = 4.5, 0.25cfm/ft²

NIST Building Infiltration & Energy Models

- Multizone infiltration and energy model
- Compared air infiltration and energy use for:
 - “typical” - no air barrier reported leakage (4x USACE)
 - “target” – good practice (40% below USACE)
- Five cities in different climate zones

NIST Building Infiltration & Energy Models

Two-Story, 24,000ft² Office Building

g

City	Annual Average Infiltration (h ⁻¹)		Gas Savings		Electrical Savings		Total Savings
	Baseline	Target					
Bismarck	0.22	0.05	\$1,854	42%	\$1,340	26%	\$3,195
Minneapolis	0.23	0.05	\$1,872	43%	\$1,811	33%	\$3,683
St. Louis	0.26	0.04	\$1,460	57%	\$1,555	28%	\$3,016
Phoenix	0.17	0.02	\$124	77%	\$620	9%	\$745
Miami	0.26	0.03	\$0	0%	\$769	10%	\$769

One-Story, 12,000ft² Retail Building

f

City	Annual Average Infiltration (h ⁻¹)		Gas Savings		Electrical Savings		Total Savings
	Baseline	Target					
Bismarck	0.20	0.02	\$1,835	26 %	\$33	2 %	\$1,869
Minneapolis	0.22	0.02	\$1,908	28 %	\$364	18 %	\$2,272
St. Louis	0.24	0.01	\$1,450	38 %	\$298	9 %	\$1,748
Phoenix	0.13	0.00	\$176	64 %	\$992	14 %	\$1,169
Miami	0.21	0.01	\$6	98 %	\$1,224	14 %	\$1,231

Emmerich and Persily 2013

Model Infiltration: Range of Envelope Leakage

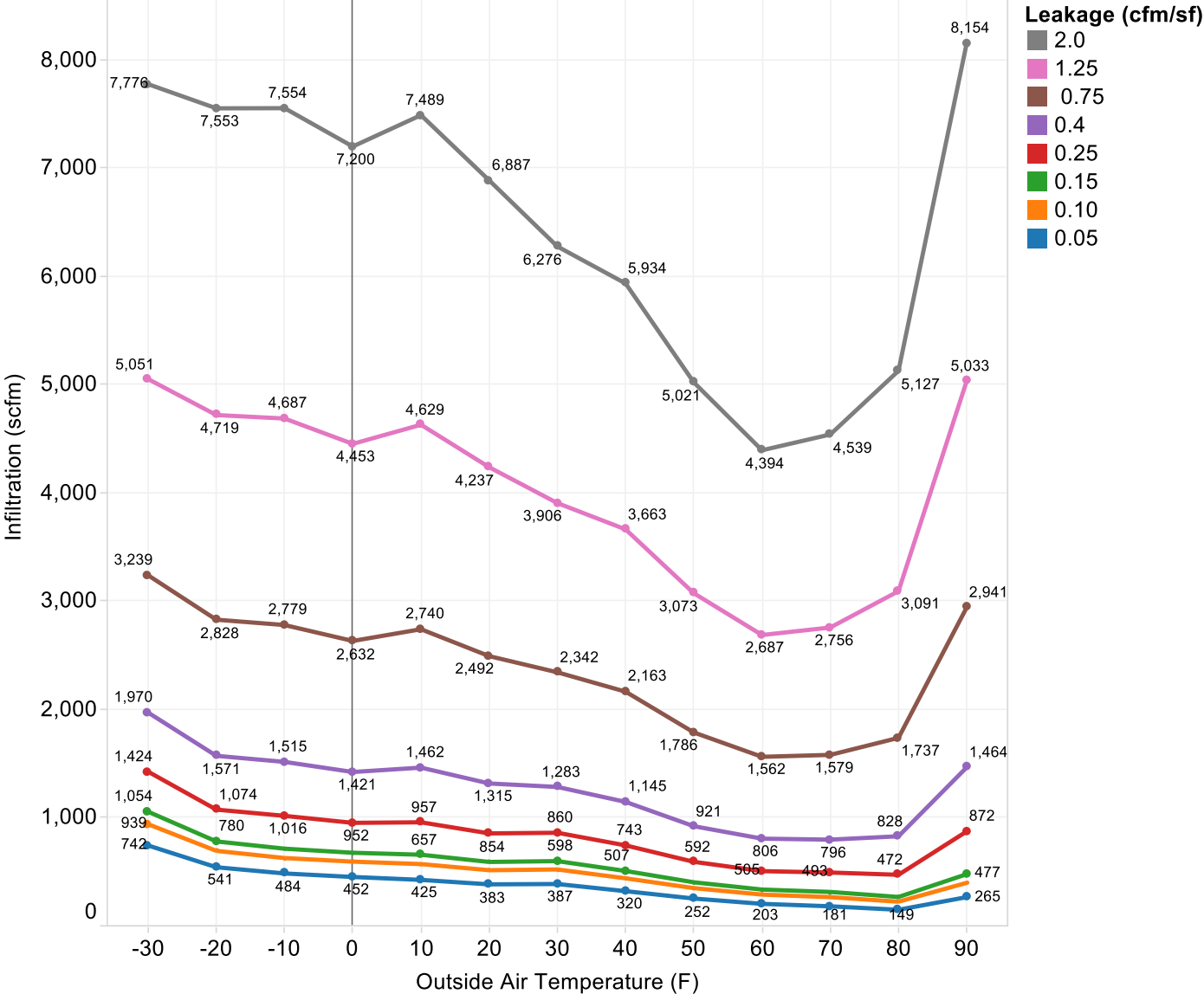

Model Infiltration: Range of Envelope Leakage

1 Story 60,560ft² Elementary School: HVAC Imbalance = 3,450 cfm

	Building Envelope Leakage (cfm@75/ft ²)							
	0.05	0.1	0.15	0.25	0.4	0.75	1.25	2
Avg Infil. (cfm)	305	417	481	708	1,094	2,077	3,539	5,751
Avg Infil. (ach)	0.03	0.03	0.04	0.06	0.09	0.17	0.29	0.47
Heat Load (therms/yr)	855	1,139	1,305	1,875	2,832	5,260	8,867	14,322
% Space Heating	2%	3%	3%	5%	7%	14%	23%	37%
Cost (\$)	\$496	\$661	\$757	\$1,087	\$1,643	\$3,051	\$5,143	\$8,306

NIST office building model:

1.0 cfm/ft² = 0.23 ach

0.1 cfm/ft² = 0.05 ach

ASHRAE Research: selection criteria

- Goal: 24 to 36 existing mid- and high-rise buildings (16 Completed)
- Non-residential
- 4 stories or higher
- Sustainability certification (14 of 16)
- Built after the year 2000
- Climate zones 2-7 (All 6 Zones Represented)

ASHRAE Research Project: leakage results

- Average = **0.29** cfm/ft²
- Green building = **0.32** cfm/ft²; others = **0.22** cfm/ft²
- Air barrier specified and envelope expert = **0.13** cfm/ft²; others = **0.39** cfm/ft²
- Unsealing HVAC penetrations increased leakage by average of **27%** with range of **2%** to **51%**

ASHRAE Research Project: leakage sites

- Roof/wall intersection
- Soffits and overhangs
- Mechanical rooms, garages, basements, loading docks
- Roll-up and overhead doors

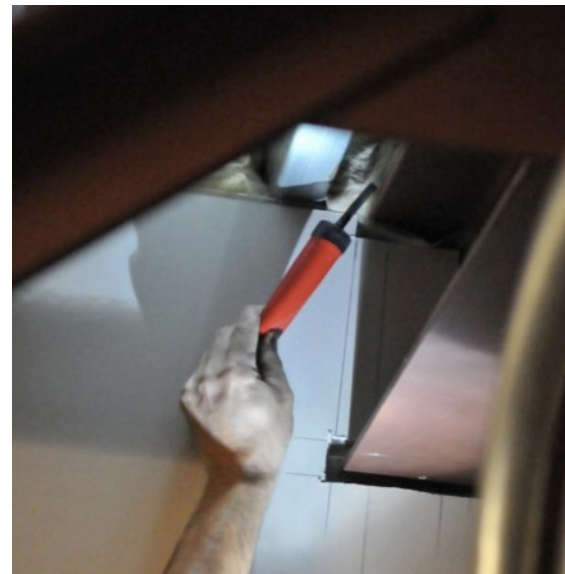
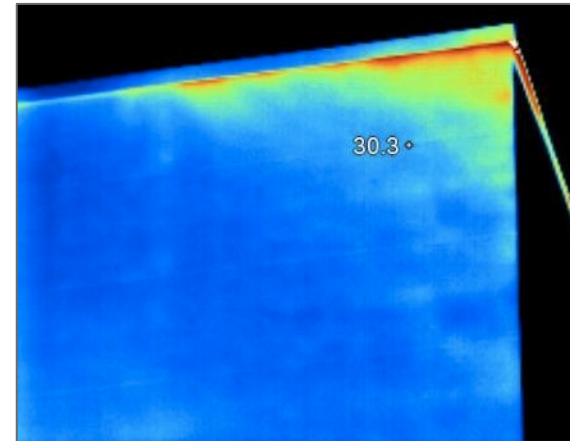

Minnesota Leakage Study: work scope

- Conduct investigations on 25 buildings: floor area of 25,000 to 500,000 ft²
- Air seal and pre/post leakage tests on ~~X~~ 7 buildings
- Continuous building pressure and HVAC operation data for 50 to 200 days
- CONTAM pre/post air flow models that include mechanical system leakage and pressure effects
- Compute infiltration/energy reductions

Building Characteristics

Building ID	Floor Area (sf)	# Stories	Constr Year	Wall Type
Elem School TF	59,558	1	1951	Masonry & corrugated metal panel
Middle School	138,887	3	1936	Cast concrete w/CMU infill
Small Office	26,927	1	1998	EFIS tip up (3 walls) and CMU block
Univ Library	246,365	3	1967	Cast concrete w/CMU infill & brick ext
Elem School PS	60,968	1	1965	CMU w/brick exterior
Library/Office	55,407	1	2007	Steel studs & brick or stone cladding



3 elementary & middle schools: 1936 to 1965 with additions 60,000 – 139,000sf



University Library 246,000sf



Small Office 27,000sf



Library/Office 55,000sf

Minnesota Leakage Study: leakage results

All 7 buildings at least 25% tighter than the US Army Corp standard of 0.25 cfm/ft²

Building ID	Floor Area (ft ²)	Envelope Area (ft ²)	Air Leakage at 75Pa				# Stories	Constr Year
		6 Sides ²	(cfm)	6 Sides (cfm/ft ²)	EqLA (ft ²)			
Elem School TF	59,558	146,977	27,425	0.19	15.2	1	1951	
Comm. College	95,000	164,844	28,881	0.18	17.2	2	1996	
Middle School	138,887	208,733	32,818	0.16	16.6	3	1936	
Small Office	26,927	65,267	9,177	0.14	4.6	1	1998	
Univ Library	246,365	171,712	23,356	0.14	13.1	3	1967	
Elem School PS	60,968	145,766	17,602	0.12	9.6	1	1965	
Library/Office	55,407	139,965	12,321	0.09	6.9	1	2007	
Minimum	26,927	65,267	9,177	0.09	4.6			
Mean	97,587	149,038	21,654	0.14	11.9			
Median	60,968	146,977	23,356	0.14	13.1			
Maximum	246,365	208,733	32,818	0.19	17.2			

Comparison to US Buildings

7 building average is 85% less than the US average, slightly less than US Army Corp average

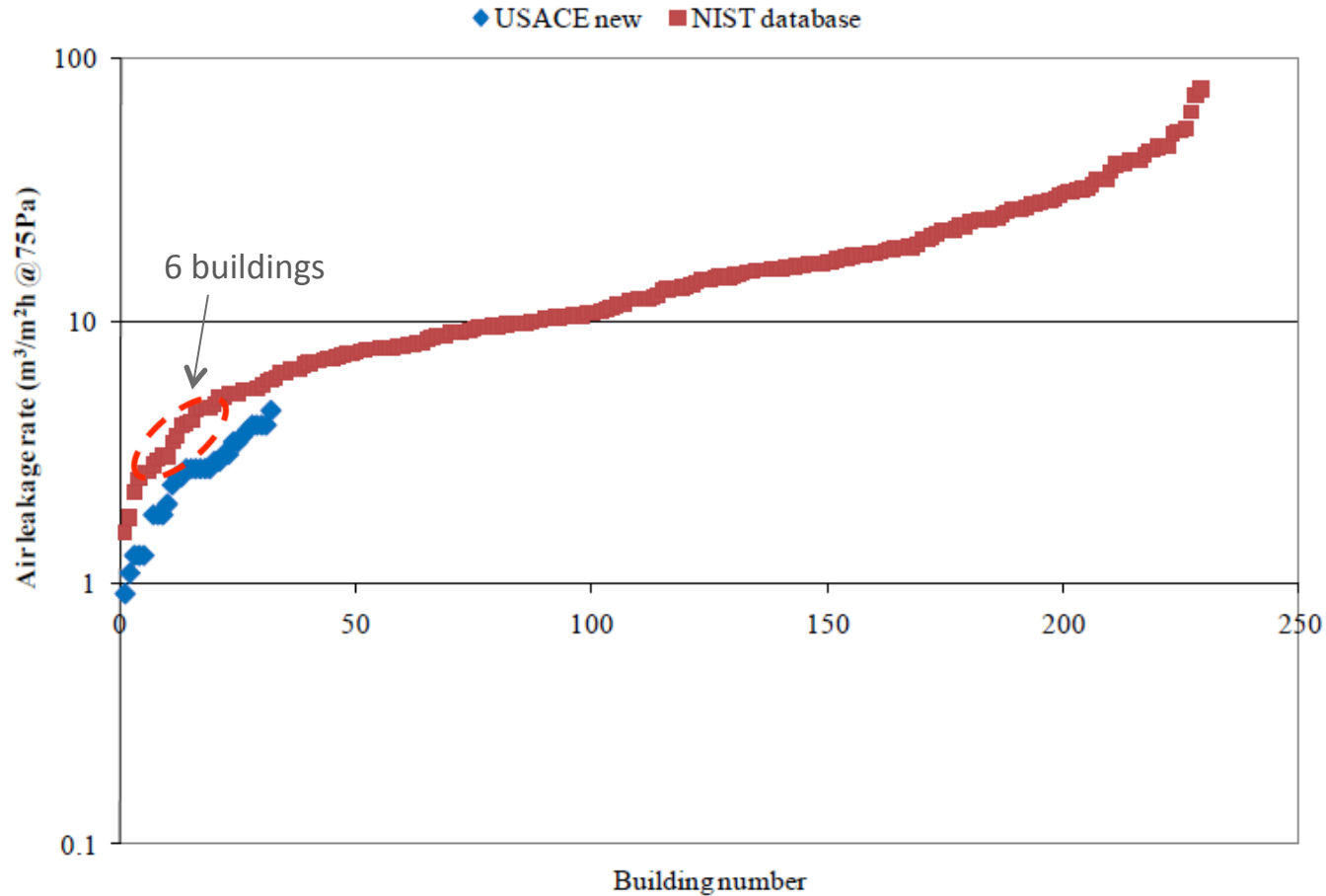

Tighter Buildings in Colder Climates?

7 building average is 85% less than the US average

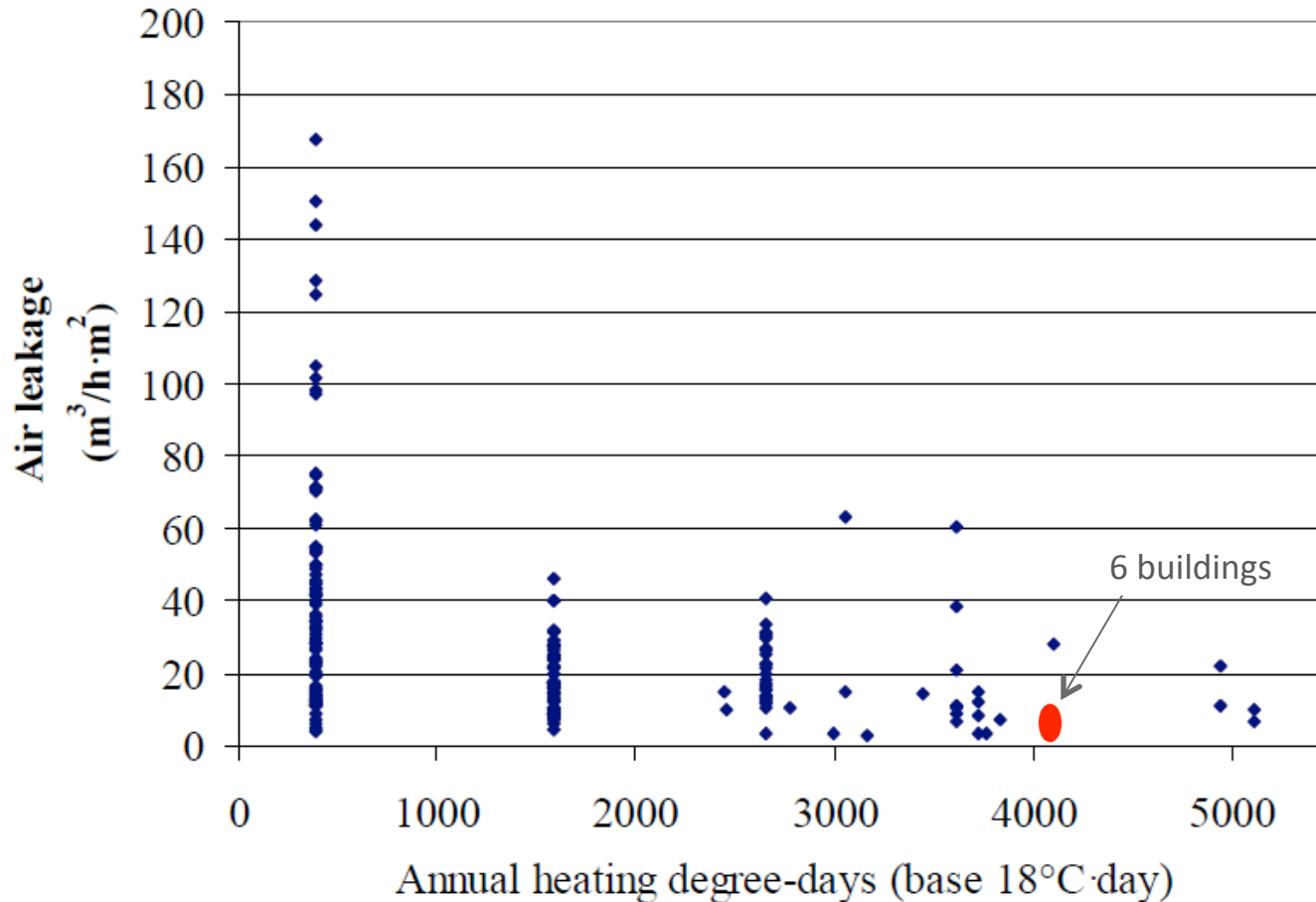

Where Were the Leaks?

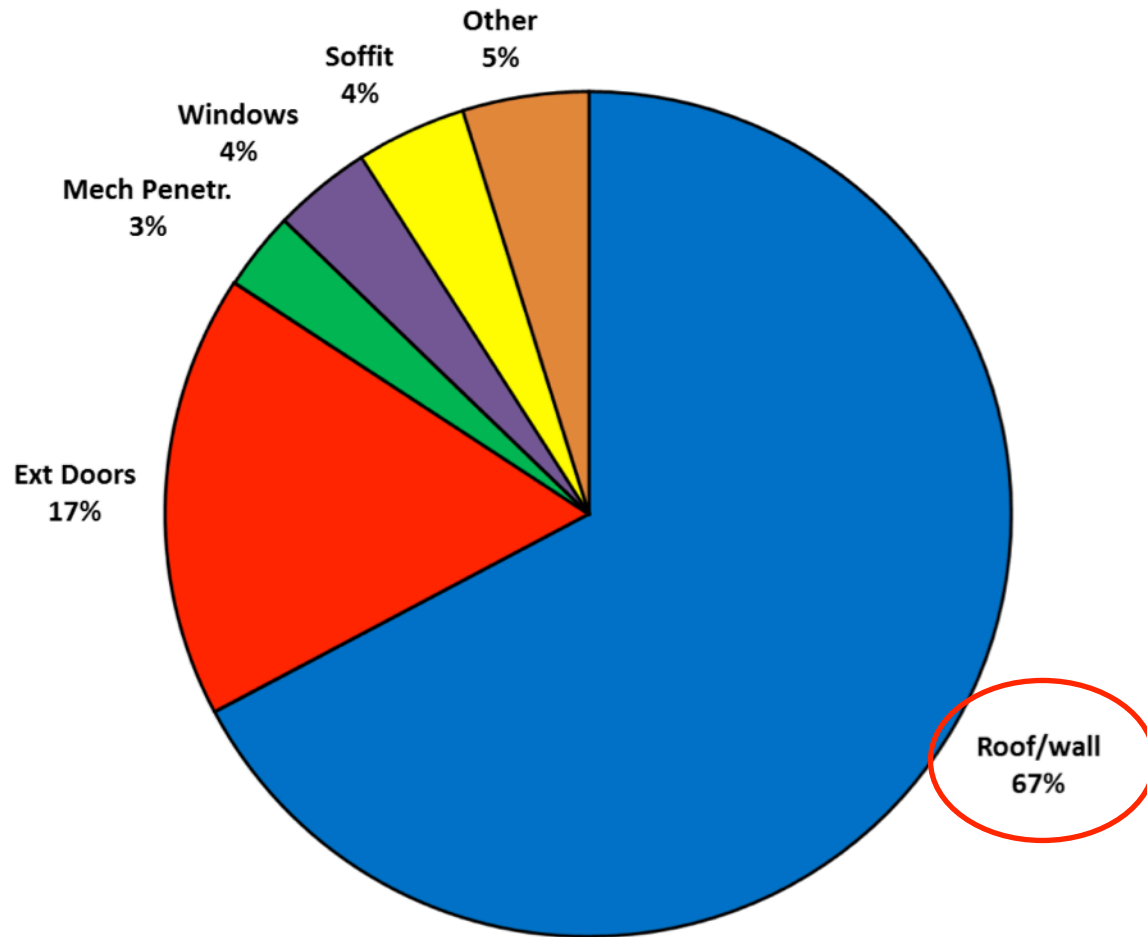

Where Were the Leaks?

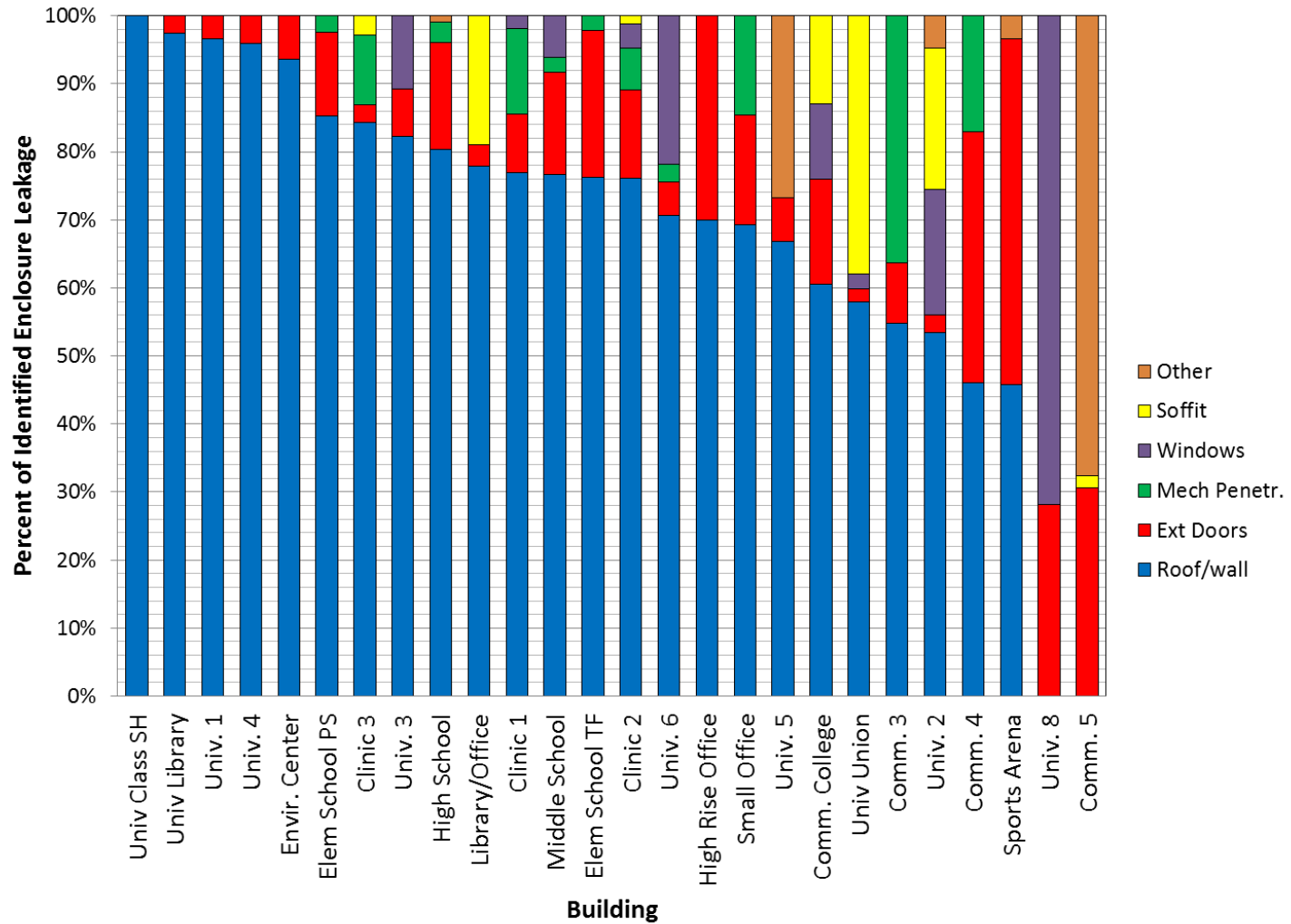

Air Sealing Focused on Roof/wall

Canopy leakage at exterior wall

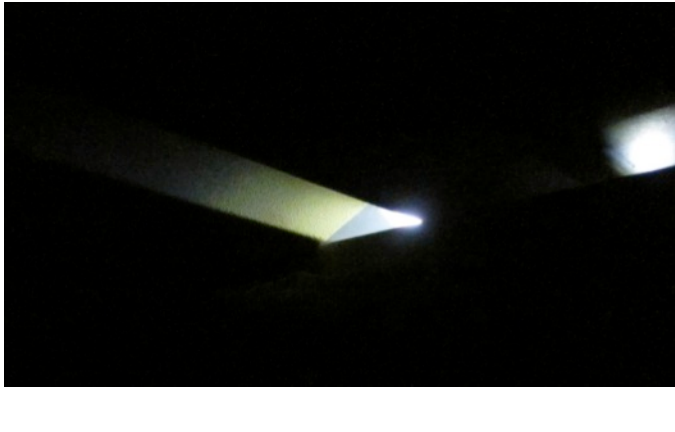
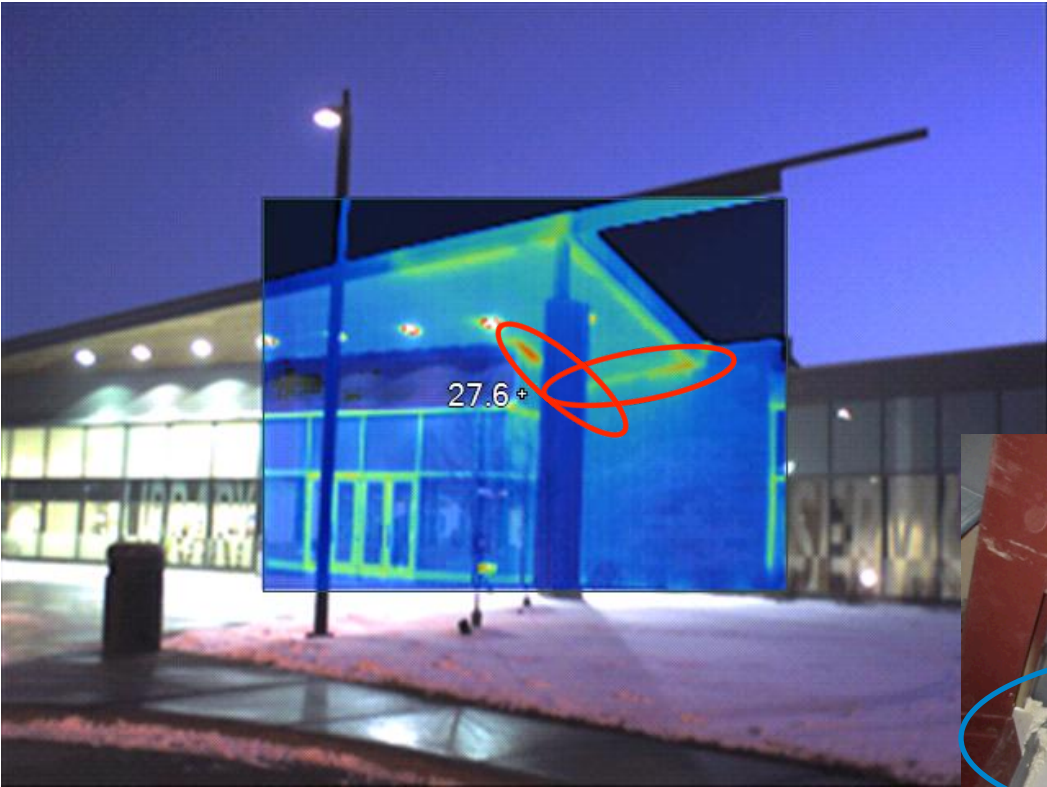

Air Sealing Focused on Roof/wall

Canopy leakage at exterior wall

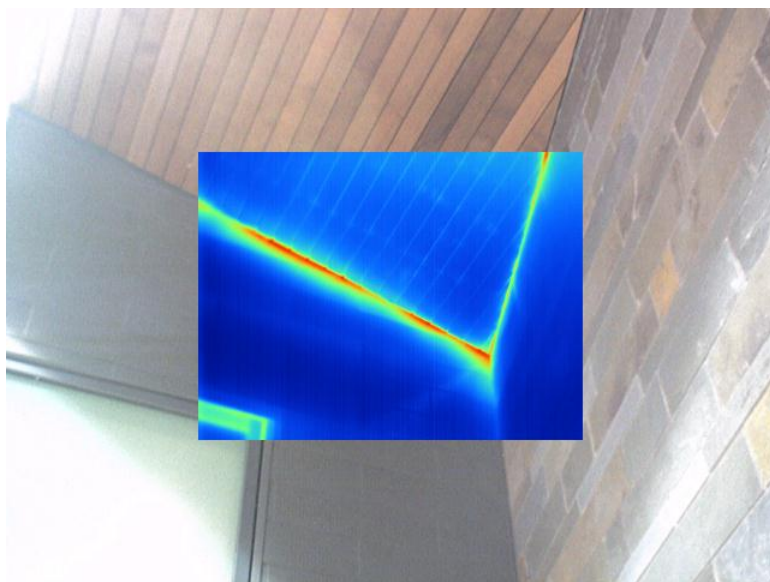

IR Before

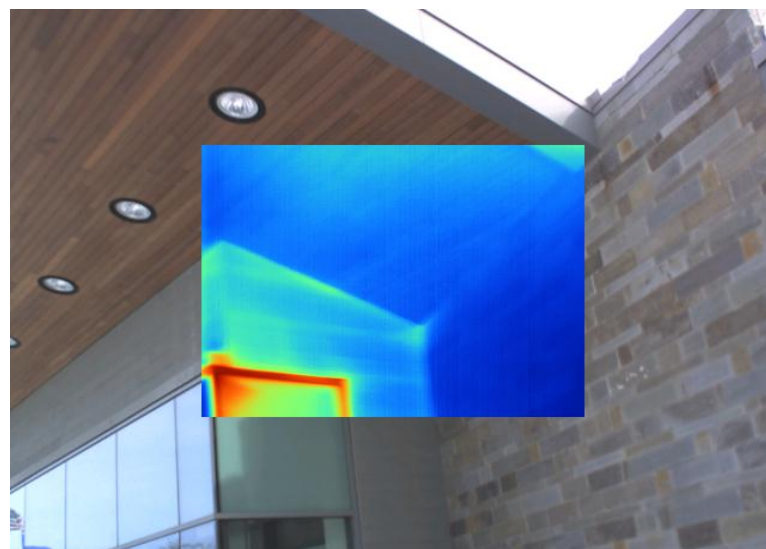

IR After

Where to look: IR view of rear CMU wall pre

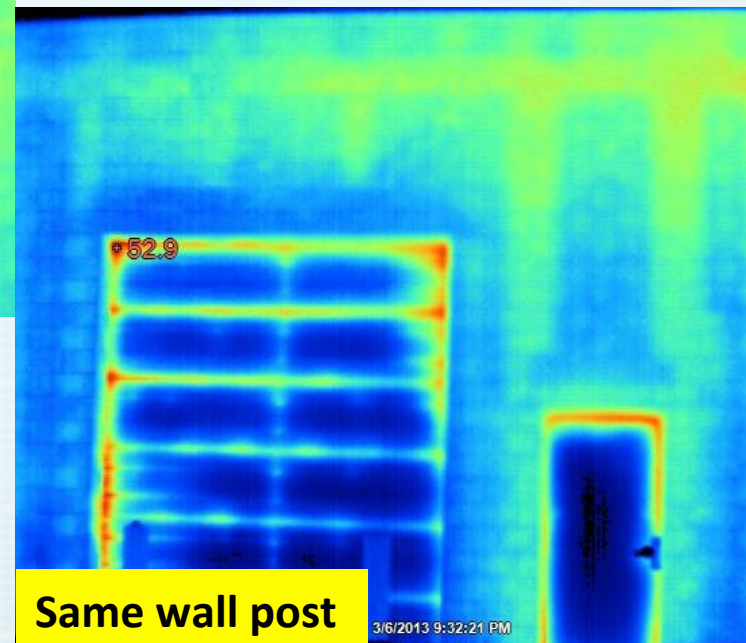
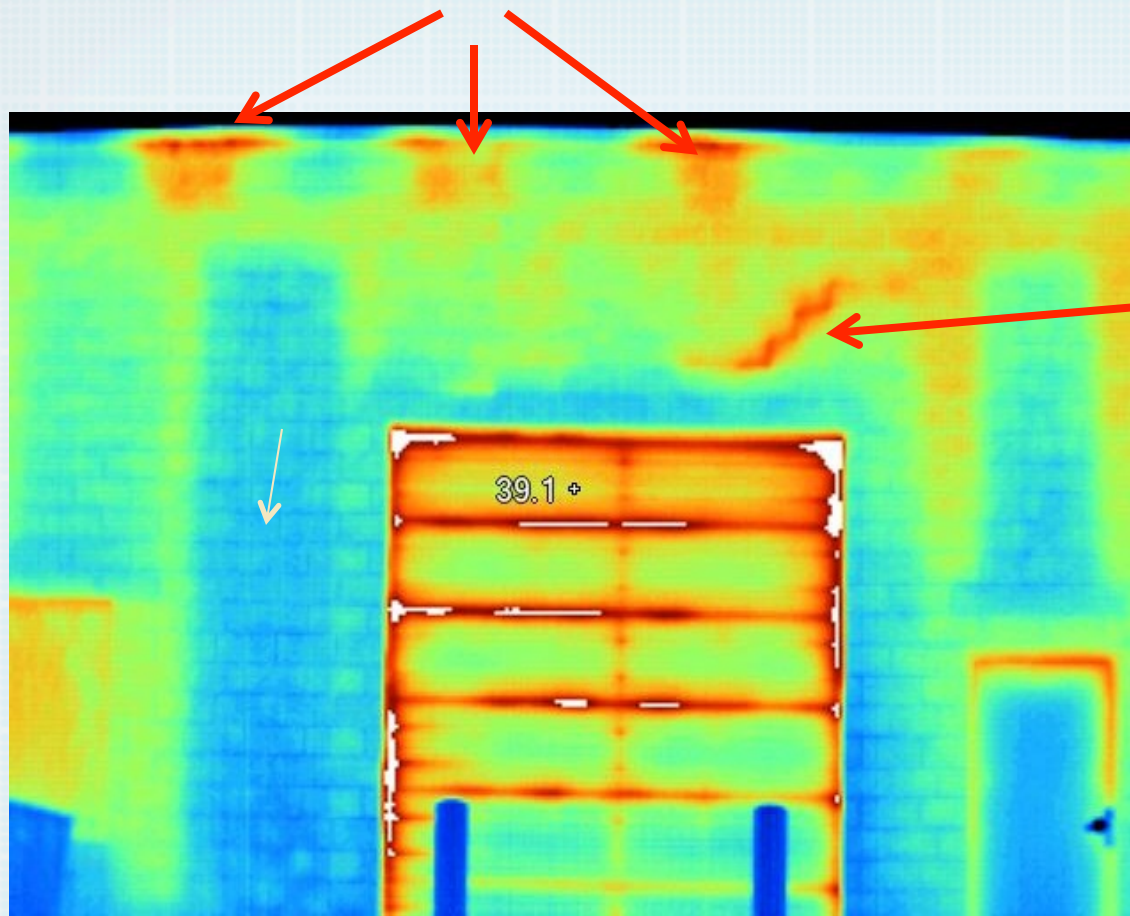

Look inside: 10 beam pockets

Open to inside



Open above to parapet cap



Smoke shows airflow



Closed cell foam fill, don't create fire hazard



$\frac{3}{4}$ cu ft foam block
max temp rise check
for building official
and owner before
injection.

Don't start a fire

See ICC ES 3228 approvals.
maintain exhaust on work
space adj. to occupied office
Sample MDI < 5ppb
Manage exposure

Beam Pockets

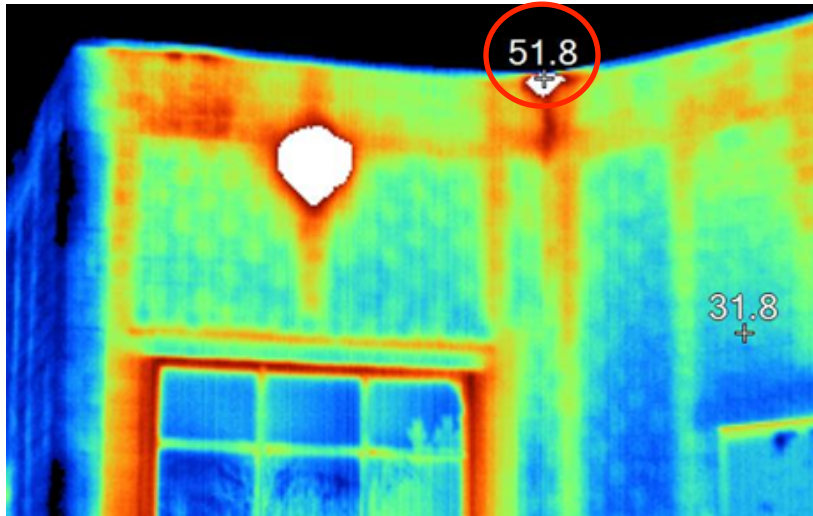

IR Before



IR After

Air Sealing Reduction

“Tight” buildings tightened by 9%

	Leakage at	Air Leakage at 75Pa			
	6 Sides	(cfm)		Reduction	
Building ID	(cfm/ft ²)	Pre	Post	(cfm)	(%)
Elem School TF	0.19	27,425	22,699	4,726	17%
Comm. College	0.18	28,881	28,133	748	3%
Middle School	0.16	32,818	28,872	3,947	12%
Small Office	0.14	9,177	8,470	708	8%
Univ Library	0.14	23,356	21,963	1,392	6%
Elem School PS	0.12	17,602	15,837	1,765	10%
Library/Office	0.09	12,321	11,369	953	8%
Minimum	0.09	9,177	8,470	708	3%
Mean	0.14	21,654	19,620	2,034	9%
Median	0.14	23,356	21,963	1,392	8%
Maximum	0.19	32,818	28,872	4,726	17%

Leakier

 Tighter

Air Sealing Reduction

More expensive to seal tighter buildings?

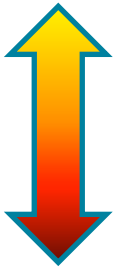
Building ID	Air Sealing Cost		
	Total	(\$/CFM75)	(\$/ft ²)
Elem School TF	\$ 18,550	\$ 3.92	\$ 6,822
Comm. College	\$ 17,845	\$ 23.86	\$ 17,273
Middle School	\$ 23,700	\$ 6.00	\$ 8,434
Small Office	\$ 4,768	\$ 6.73	\$ 10,058
Univ Library	\$ 15,918	\$ 11.43	\$ 65,159
Elem School PS	\$ 26,700	\$ 15.13	\$ 38,132
Library/Office	\$ 1,152	\$ 1.21	\$ 1,297
Median	\$ 17,845	\$ 6.73	\$ 10,058

Leakier

 Tighter

Air Sealing Reduction

Contractor estimates better for leakier buildings?

Building ID	Leakage Area				Sealed Area (sf)		
	EqLA (ft ²)		Reduction		Contractor Estimated		Meas/Est
	Pre	Post	(ft ²)	(%)	Roof/Wall	Total	
Elem School TF	15.2	12.5	2.7	18%	8.84	11.49	0.31
Comm. College	17.2	16.2	1.0	6%	5.47	5.47	0.19
Middle School	16.6	13.8	2.8	17%	11.73	14.98	0.24
Small Office	4.6	4.1	0.5	10%			
Univ Library	13.1	12.8	0.2	2%			
Elem School PS	9.6	8.9	0.7	7%	14.45	16.94	0.05
Library/Office	6.9	6.0	0.9	13%			

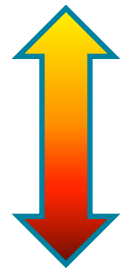
Leakier



Tighter

Building Leakage < Estimated sealing

Air Sealing Energy Savings

Modeled Infiltration and Energy Savings

Building ID	Space Heat Gas Use (Therms/yr)		
	Total	Infiltration	Infil/Total
Elem School TF	40,224	2,389	6%
Comm. College	32,095	3,402	11%
Middle School	44,469	7,779	17%
Small Office		684	
Univ Library		192	
Elem School PS	26,563	2,387	9%
Library/Office	18,108	2,829	16%
Minimum			6%
Mean			12%
Median			11%
Maximum			17%

Air Sealing Energy Savings

Modeled Infiltration and Energy Savings

Building ID	Space Heat Gas Use (Therms/yr)			Gas Savings		Avg Infil (cfm)	Leakage Red. (%)
	Total	Infiltration	Infil/Total	(Therm/yr)	(\$/yr)		
Elem School TF	40,224	2,389	6%	549	\$319	1,296	17%
Comm. College	32,095	3,402	11%	174	\$105	1,730	3%
Middle School	44,469	7,779	17%	905	\$525	4,330	12%
Small Office		684		39	\$24	964	8%
Univ Library		192		11	\$6	249	6%
Elem School PS	26,563	2,387	9%	223	\$129	1,453	10%
Library/Office	18,108	2,829	16%	107	\$68	1,477	8%
Minimum			6%	11	\$6	249	3%
Mean			12%	287	\$168	1,643	9%
Median			11%	174	\$105	1,453	8%
Maximum			17%	905	\$525	4,330	17%

Air Sealing Energy Savings



Modeled Infiltration and Energy Savings

Building ID	Gas Savings		Electric Savings		Total (\$/yr)	Leakage Red. (%)	Cost (\$)	Payback (years)
	(Therm/yr)	(\$/yr)	(kWh/yr)	(\$/yr)				
Elem School TF	549	\$319	1,034	\$101	\$419	17%	\$18,550	44
Comm. College	174	\$105	232	\$23	\$127	3%	\$17,845	140
Middle School	905	\$525	2,523	\$246	\$771	12%	\$23,700	31
Small Office	39	\$24	18	\$2	\$26	8%	\$4,768	182
Univ Library	11	\$6	79	\$0	\$6	6%	\$15,918	2,872
Elem School PS	223	\$129	487	\$47	\$177	10%	\$26,700	151
Library/Office	107	\$68	-232	-\$24	\$44	8%	\$1,152	26
Minimum	11	\$6	-232	-\$24	\$6	3%	\$1,152	26
Mean	287	\$168	592	\$56	\$224	9%	\$15,519	492
Median	174	\$105	232	\$23	\$127	8%	\$17,845	140
Maximum	905	\$525	2,523	\$246	\$771	17%	\$26,700	2,872

Able to seal “tight” buildings, but work was not cost effective

Building Pressure Measurements

Average building pressure at ground level (Pa)

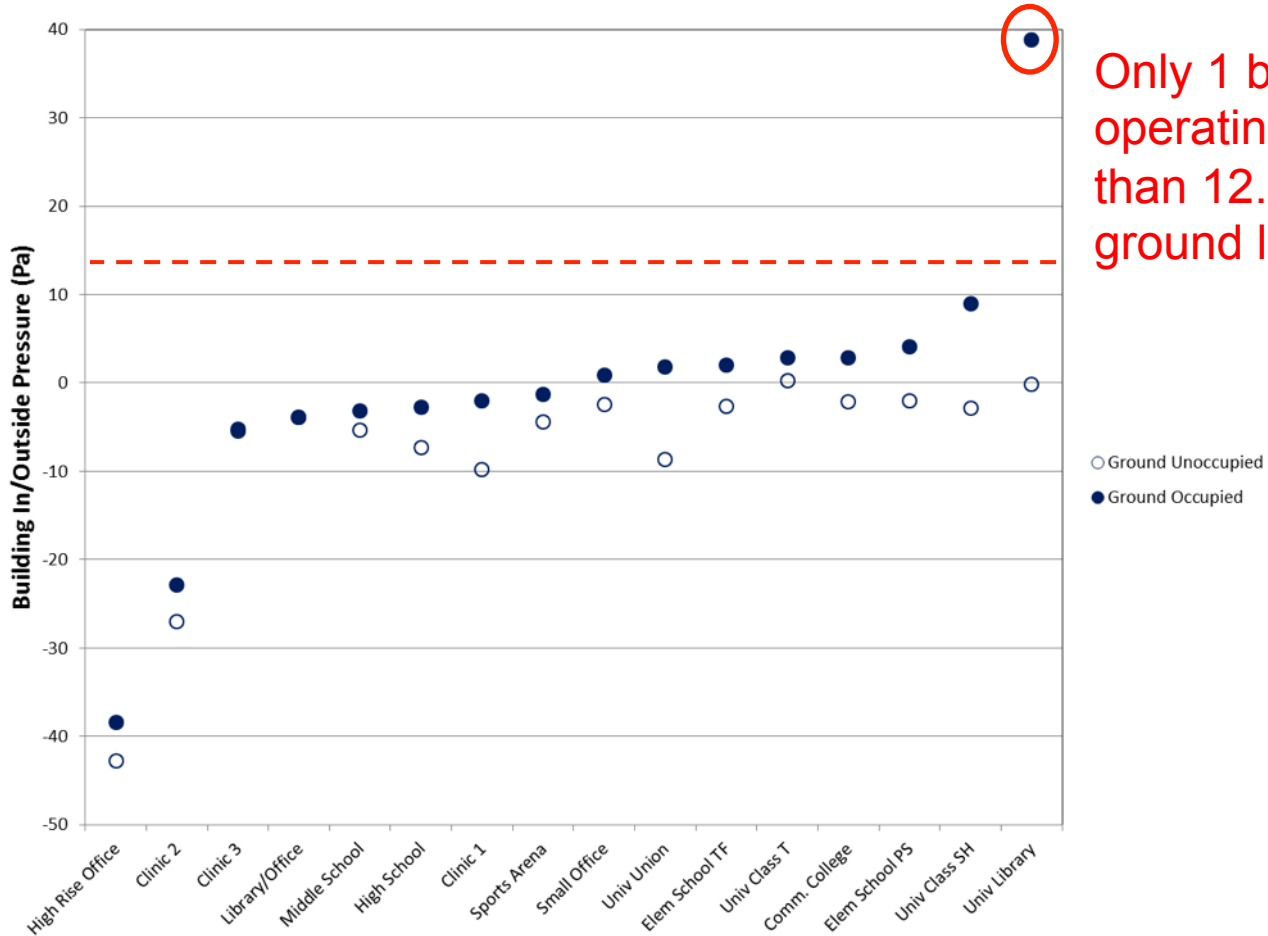

Only 1 building operating greater than 12.5Pa at ground level

20F < outside temp <= 45F

Building Pressure Measurements

Average building pressure at ground level (Pa)

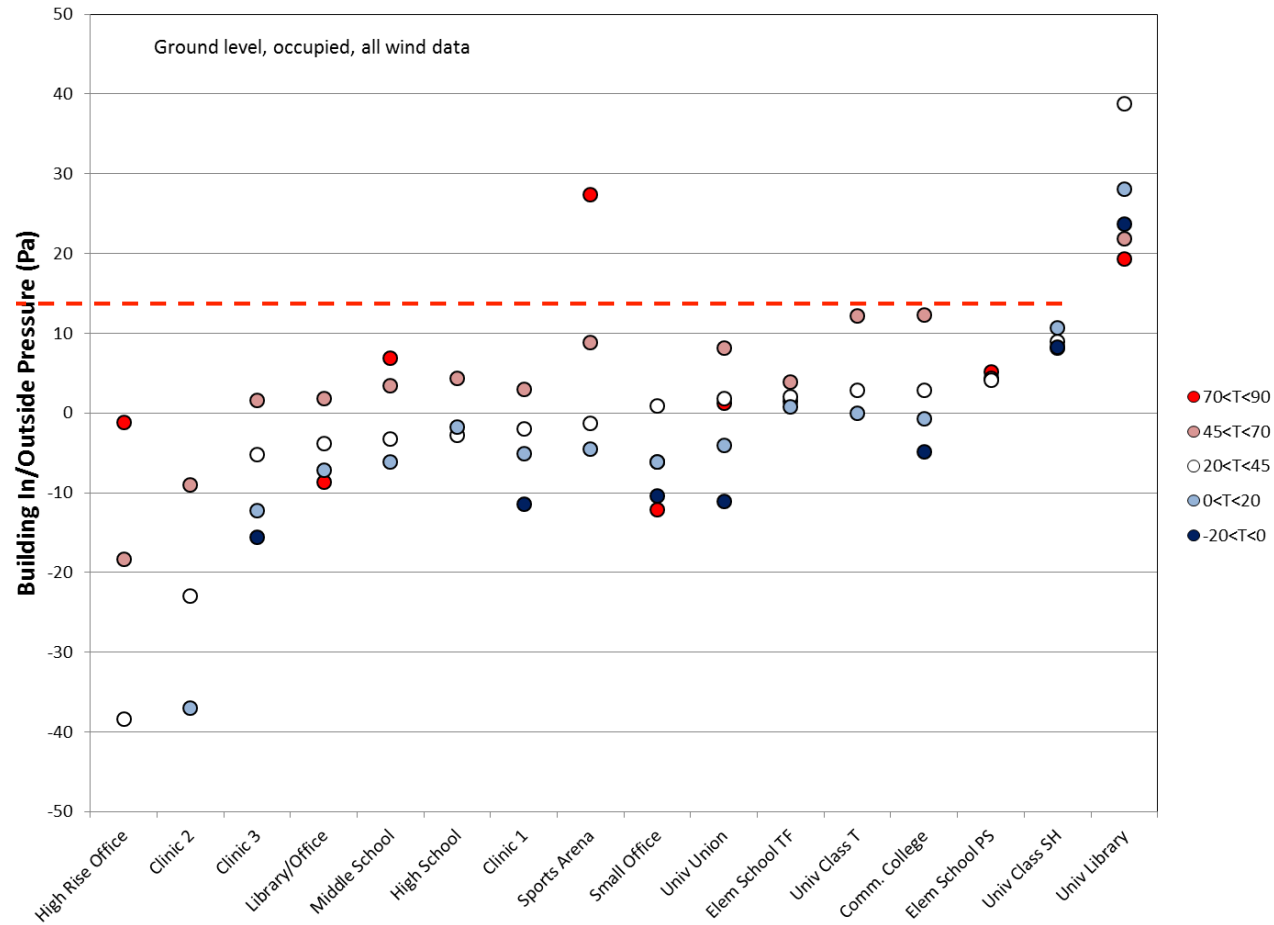

Building Pressure Measurements

Difference between occupied and unoccupied pressure (Pa)

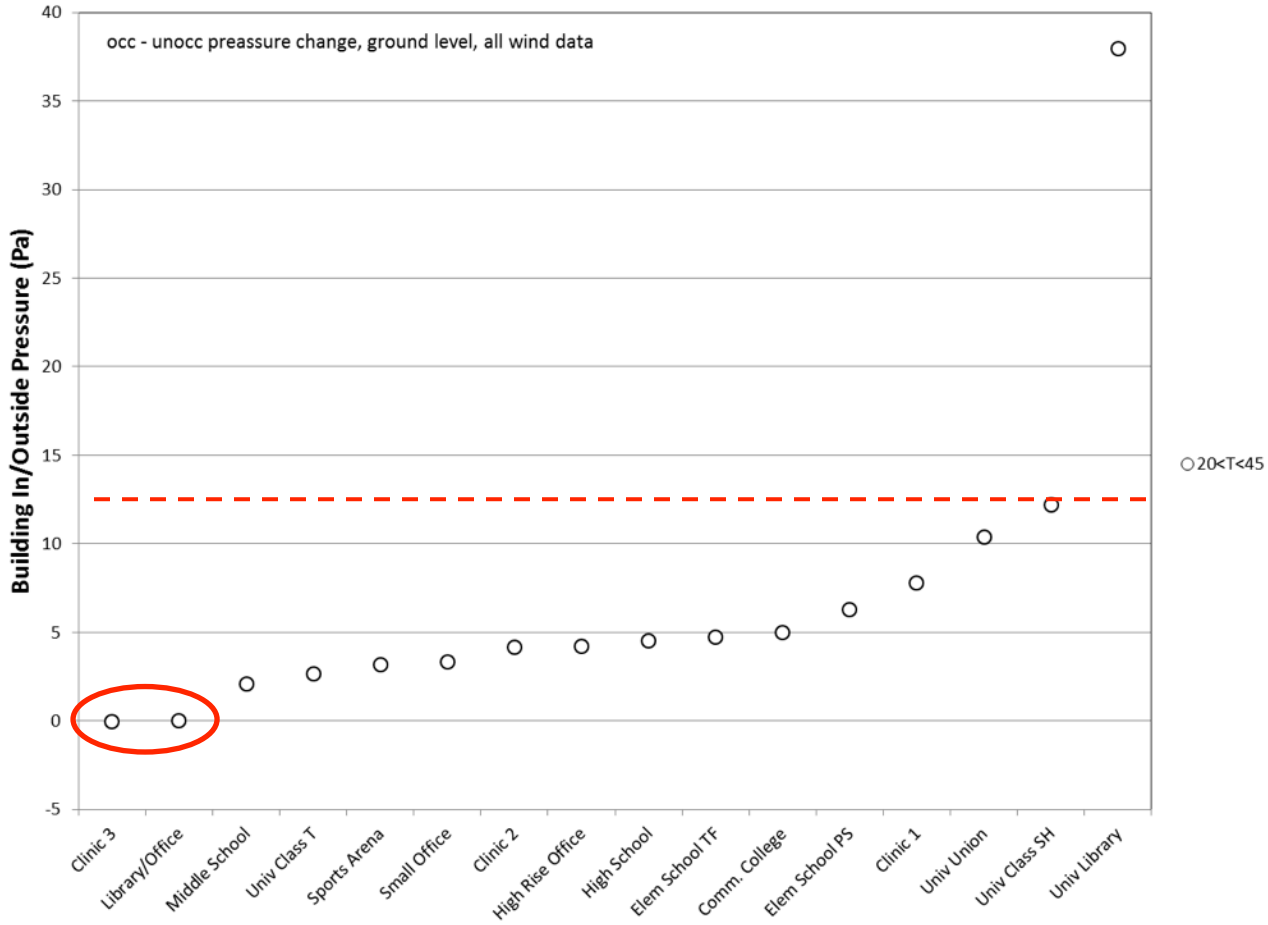

Pressure increase for almost all buildings

20F < outside temp <= 45F

Building Pressure Measurements

Difference between occupied and unoccupied pressure (Pa)

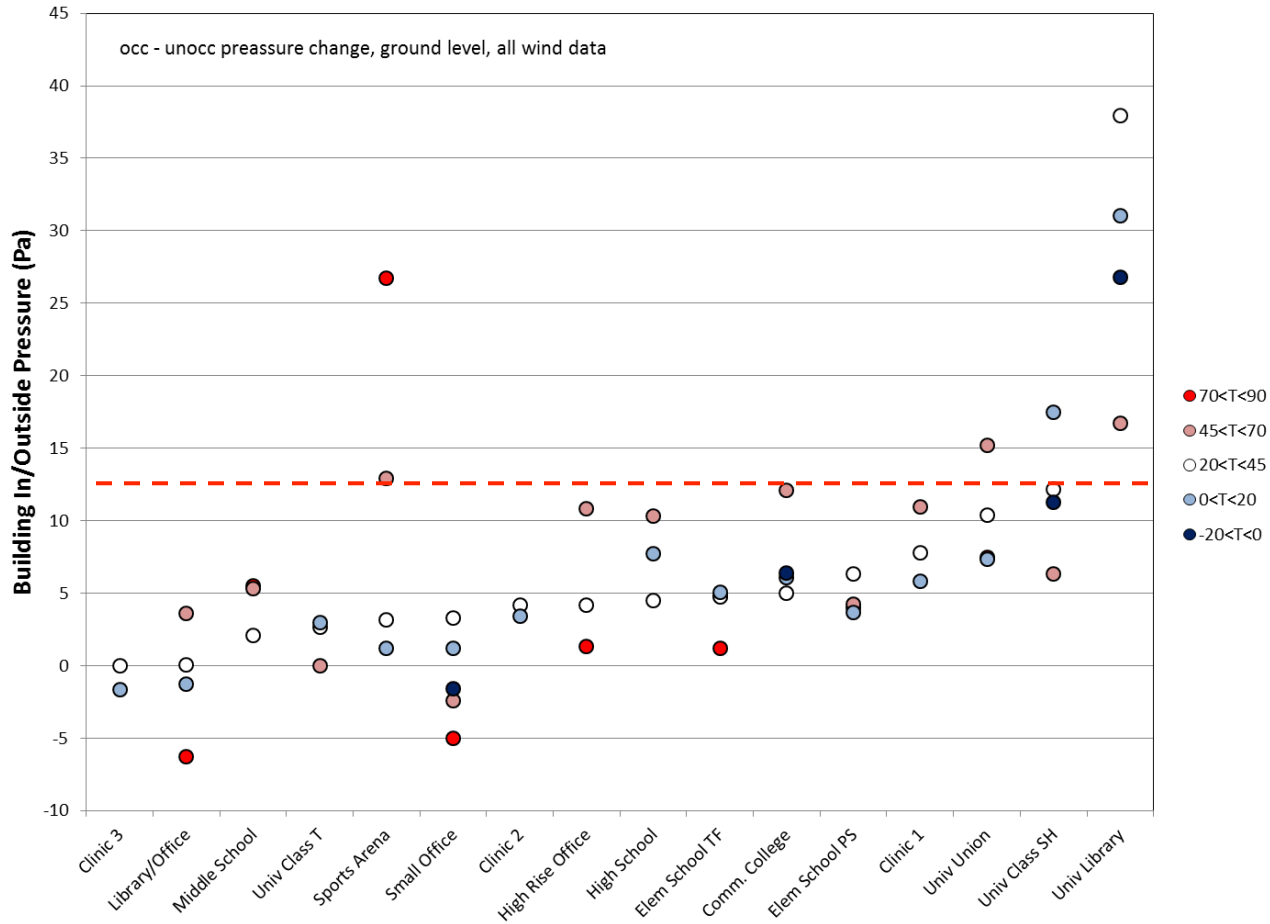

20F < outside temp <= 45F

Computing Savings For Your Project

- Can we divide cfm50 by 20 to get savings?
- It is not that simple for larger buildings
- HVAC pressurization effects savings
- Greater savings for taller buildings, open terrain, distance from neutral level, floor compartmentalization
- Internal heat gain = cooling more important
- **Developing spreadsheets for savings calculations**

Computing Savings For Your Project

Three Story Commercial Building

- Typical pressurization = 10% less
6Pa = 35% less
12.5Pa = 60% less
- 1 story = 40% less;
story = 30% more;
10 story = 80% more
- Urban wind shielding = 35% less
Open wind shielding = 70% more

5

Office Building Model: Heating & Cooling

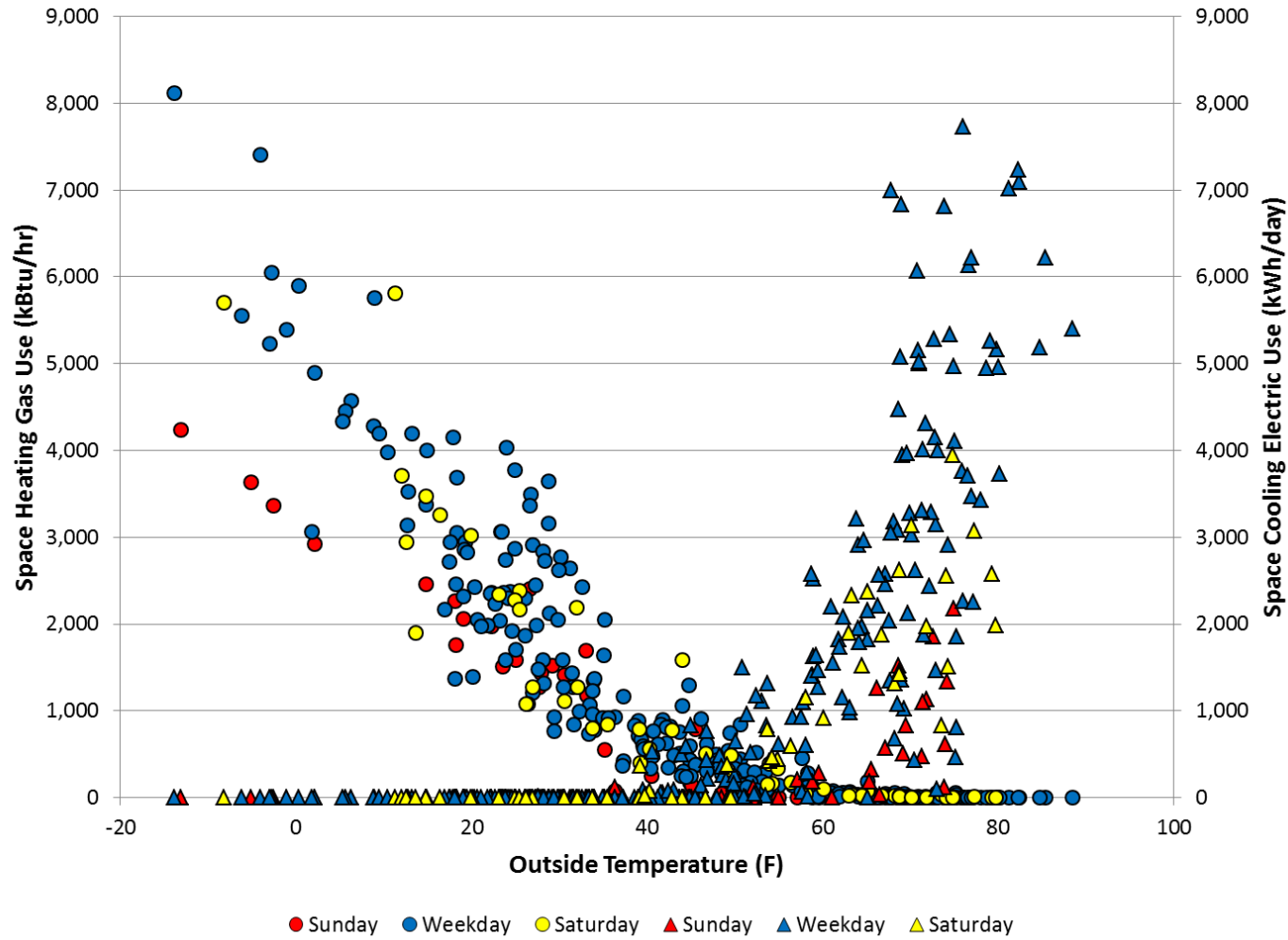

Mechanical System Leakage

Part of building envelope when not operating



Mechanical System Leakage

Part of building envelope when not operating

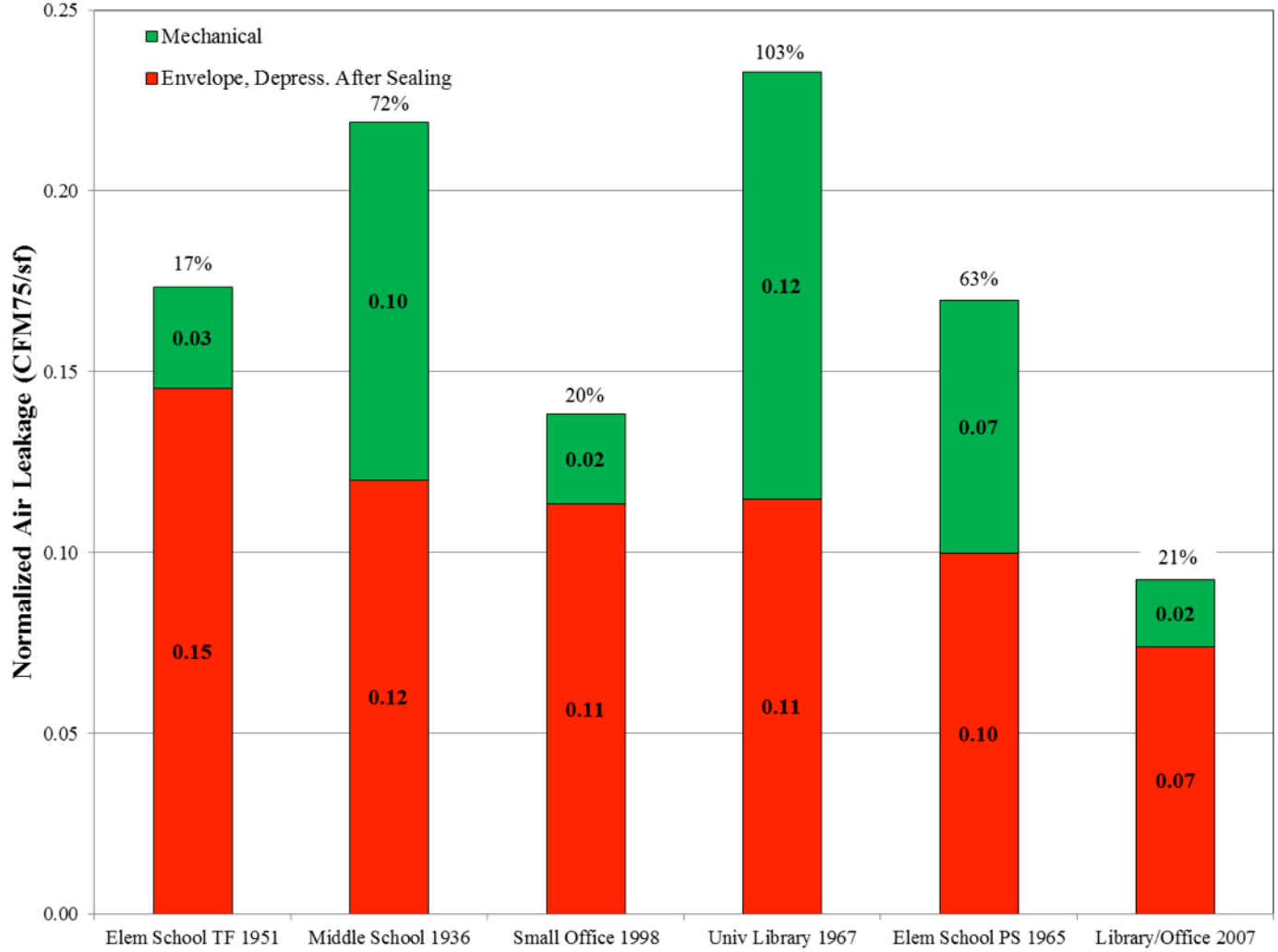

Mean
49%
0.06 cfm/ft²
(6 sides)

Range
17% to 103%
0.02 to 0.12 cfm/ft²

Two most recently built (1998 and 2007) had low leakage



Summary

- Tight buildings: 85% tighter than U.S. average & at least 25% below Army Corp standard – due to cold climate location?
- Sealing = 9% reduction, more reduction and less expensive for leakier buildings
- Contractor over-estimated sealing area
- Long paybacks for air sealing work
- Including mechanical systems increased leakage by 17 to 103% (0.02 to 0.12 cfm/ft²)
- HVAC systems tend to pressurize buildings. Not as great as typical design practice

When Is Air Sealing Worthwhile?

- You can see out the envelope gaps & leak is accessible
- Taller (5+ stories) in open terrain
- Reported problem that is likely to be caused by air leakage
- You live in portion of US that hasn't had to worry about infiltration

Other Opportunities

- Older/leaky dampers (cost?)
- Building pressure control

Thank you!



Building Pressure Measurements

Average building pressure at ground level (Pa)

	-20 < OAT < 0		0 < OAT < 20		20 < OAT < 45		45 < OAT < 70		70 < OAT < 90	
	<i>unoccupied</i>	<i>occupied</i>	<i>unoccupied</i>	<i>occupied</i>	<i>unoccupied</i>	<i>occupied</i>	<i>unoccupied</i>	<i>occupied</i>	<i>unoccupied</i>	<i>occupied</i>
Comm. College	-10	-4	-6	0	-2	3	0	12		
Elem School PS			-4	0	-2	4	0	4	1	5
Middle School			0	-5	-6	-3	-3	2	1	6
High School			-10	-2	-7	-3	-6	4		
Elem School TF	-6		-4	1	-3	2	-1	3	0	1
Library/Office			-6	-7	-4	-4	-2	2	-3	-9
Sports Arena			-6	-4	-4	-1	-4	9	1	27
Univ Class T	6		-3	0	0	3	12	12		
Univ Union		-11	-11	-4	-9	2	-7	8	-6	1
High Rise Office					-48	-44	-32	-21	-2	-1
Clinic 1		-10	-11	-5	-10	-2	-9	2		
Clinic 2	-49		-39	-35	-27	-23		-11		
Clinic 3		-13	-9	-11	-6	-6		1		
Univ Class SH	0	11	-6	11	-3	9	1	7		
Maximum	6	11	0	11	0	9	12	12	1	27
Minimum	-49	-13	-39	-35	-48	-44	-32	-21	-6	-9
Median	-6	-10	-6	-4	-5	-2	-2	4	0	1

No buildings operating greater than 10Pa at ground level

Most have higher pressure during occupied hours

Building Pressure Measurements

Average building pressure at ground level (Pa)

	20 < OAT < 45		
Site	Unoccupied	Occupied	Difference
High Rise Office	-44.4	-28.1	16.3
Clinic 2	-29.7	-24.3	5.4
Clinic 1	-10.5	-3.4	7.1
Univ Union	-8.8	0.9	9.7
High School	-7.4	-2.8	4.6
Univ Class SH	-5.7	7.0	12.7
Middle School	-5.4	-4.5	0.9
Clinic 3	-5.4	-6.4	-1.0
Sports Arena	-4.4	-1.3	3.2
Small Office	-4.0	2.1	6.1
Library/Office	-4.0	-3.5	0.5
Comm. College	-3.1	1.9	5.0
Elem School TF	-2.7	1.7	4.4
Elem School PS	-2.3	2.4	4.6
Univ Library	-1.9	37.7	39.6
Univ Class T	-0.7	0.2	0.9
Minimum	-44.4	-28.1	-1.0
Median	-4.9	-0.5	4.8
Average	-8.8	-1.3	7.5
Maximum	-0.7	37.7	39.6

Most have higher pressure during occupied hours

Only 1 building operating greater than 10Pa at ground level