

WELCOME



Recommended Window Installation

2 credits

Minnesota Department of Labor and Industry

MARVIN 
Windows and Doors

Built around you.®

Copyright Notice

This presentation is protected by U.S. and International copyright laws. Reproduction and distribution of the presentation without written permission of the sponsor is prohibited.

© Marvin Windows and Doors

Course contents

- Overview: Hands-on Presentation

Installing a Window

- Recommendations (Installation Instructions)
- Choices – Right Window for Right Application
 Interfacing Window with Wall Condition
- Level, Plumb, Square, and True
- Clearance Provisions and Shimming
- Sill Pan Flash Choices
- Materials and Compatibility
- Proper Flashing and Perimeter sealing

Course Overview

- Overview: Hands-on Presentation
- R.O. Clearance provisions
- Sill Pan Flash Types
- Weather seal alignment
- Performance and Operation
- Level, Plumb, Square, and True
- Shimming
- Sealing
- Flashing
- Final Inspection for Operation

Course goals

- General Knowledge of Windows
- Knowledge of Barrier Systems
- Window Install Methods A,B,A1,B1
- Weatherboard fashion and flashing techniques
- Making choices of materials to be used in Installation

In Reference to and Recommended

ASTM E2112-07

Manufacturer



Designation: E 2112 - 07

Standard Practice for Installation of Exterior Windows, Doors and Skylights¹

This standard is issued under the Exact Designation E 2112; the number immediately following the designation indicates the year of original adoption or, in the case of revision, the year of last revision. A number in parentheses indicates the year of last approval. A superscripted epsilon (ϵ) indicates an editorial change since the last revision or approval.

INTRODUCTION

This document is intended to provide technical guidance to organizations that are developing training programs for installers of fenestration units in low-rise residential and light commercial structures. The majority of fenestration units selected for installation in these types of structures are certified as meeting specified performance characteristics in standardized laboratory testing. Experience indicates, however, that the performance of fenestration installations is frequently significantly inferior to the performance of the manufactured units in laboratory testing. Installation of fenestration units can significantly influence in-service performance.

The requirements promulgated in this practice have, by consensus, (of individuals with specialized knowledge concerning installation of fenestration units) been identified as necessary to ensure that as-installed performance is roughly equivalent to performance in laboratory testing. The task group responsible for development of this practice recognizes that building owners sometimes, accept as adequate, in-service performance of fenestration installations that are significantly inferior to those of the units in laboratory testing. This practice is not intended for use in such circumstances, where owner expectations are modest. The intent of this practice is to provide guidance to those concerned with ensuring that as-installed performance is comparable to the capabilities of the units installed for a solid majority of installations.

A particularly noticeable behavior that indicates deficiencies in installation is rainwater leakage. Rainwater leakage has been the leading reason for dissatisfaction of building owners with performance of fenestration installations. For this reason, this practice places greater emphasis on preventing or limiting rainwater leakage than on any other single performance characteristic.

This practice emphasizes that the water-shedding surfaces of fenestration units must be adequately integrated with adjacent water-shedding surfaces of the building envelope. It does not, however, attempt to promulgate requirements for water-shedding surfaces of building envelopes other than those interfacing with fenestration units. The standard assumes that the basic design of the building's water-shedding system is adequate, that is, that either (1) there is a high probability that the outermost building surface will dependably prevent all water entry, or (2) the building envelope incorporates an effective concealed barrier that will dependably prevent further intrusion of incidental water that breaches the outermost surface. The practice further assumes that fenestration units can be dependably sealed to, and integrated with, at least one of these surfaces. If the basic design of the building's water-shedding system is inadequate, or does not allow for reliable integration of fenestration units into it, competent installation of the units is unlikely to nullify these deficiencies.

1. Scope

1.1 This practice covers the installation of fenestration products in new and existing construction. For the purpose of

this practice, fenestration products shall be limited to windows, sliding patio-type doors, swinging patio type doors, and skylights, as used primarily in residential and light commercial buildings.

1.2 This practice assumes that the installer possesses basic woodworking skills and an understanding of wall and roof construction, sheet metal work, and joint sealant practices.

1.3 This practice attempts to instruct and familiarize the installer with the concepts of both Barrier Systems and Membrane/Drainage Systems, in order to ensure the continuity

¹ This practice is under the jurisdiction of ASTM Committee E06 on Performance of Buildings and is the direct responsibility of Subcommittee E06.31 on Performance of Windows, Doors, Skylights and Curtain Walls.

Current edition approved Feb. 1, 2007. Published March 2007. Originally approved in 2001. Last previous edition approved in 2005 as E 2112 - 05.

Clad Window Installation Standard Wood Frame Construction

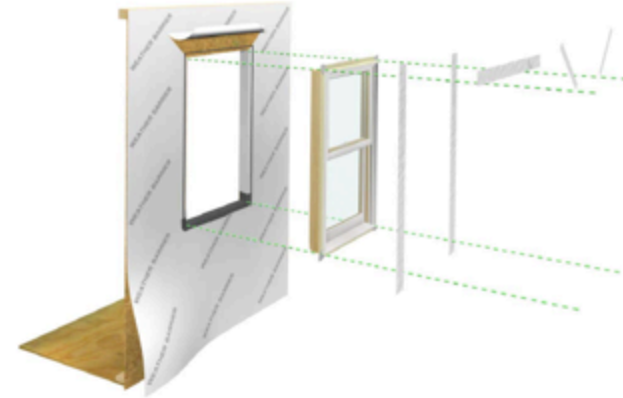

These instructions are applicable for the following aluminum clad window products:

Clad Ultimate Casement Family

Clad Tilt-Turn/Inswing Casement/Hopper

Clad Ultimate Double Hung Family

Clad Round Top

Clad Polygon

Clad Glider

ABSTRACT: Please read these instructions in their entirety before beginning to install your Marvin window product. These installation instructions demonstrate the installation of a Marvin aluminum clad window in new wood frame construction using an industry approved water management system. For installation using other construction methods, such as remodeling, replacement, and recessed openings refer to "ASTM E2112-01, Standard Practice for Installation of Exterior Windows, Doors and Skylights," for installation suggestions. Information for ASTM E2112 can be found on the ASTM website, www.astm.org.

For product specific issues, service instructions and other field service guides, refer to the Marvin Service Manual, visit our website at www.marvin.com, or contact your Marvin representative.

Regional standard practices, environmental conditions, and codes may vary and supersede the procedures contained within. The responsibility for compliance is yours: the installer, inspector, and owner(s).

The procedures within these instructions are consistent with those used in testing to achieve the advertised DP rating.

Installation

In Reference to and Recommended

Rough Opening Prep

Manufacturer

Window Rough Opening Prep and Flashing
Method A1 - Membrane Drainage System

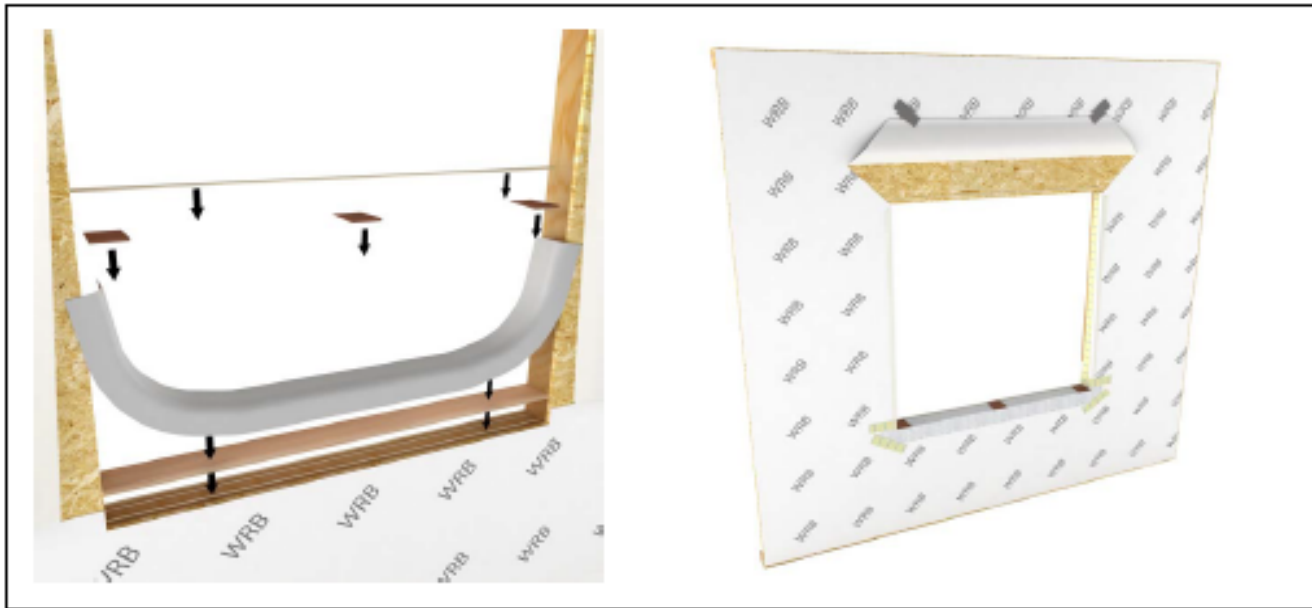

Installation

Manufacturer's Recommendations

ABSTRACT: Please read these instructions in their entirety before beginning to install your Marvin window product. These installation instructions demonstrate the installation of a Marvin aluminum clad window in new wood frame construction using an industry approved water management system. For installation using other construction methods, such as remodeling, replacement, and recessed openings refer to "ASTM E2112-01, Standard Practice for Installation of Exterior Windows, Doors and Skylights," for installation suggestions. Information for ASTM E2112 can be found on the ASTM website, www.astm.org.

For product specific issues, service instructions and other field service guides, refer to the Marvin Service Manual, visit our website at www.marvin.com, or contact your Marvin representative.

Regional standard practices, environmental conditions, and codes may vary and supersede the procedures contained within. The responsibility for compliance is yours: the installer, inspector, and owner(s).

The procedures within these instructions are consistent with those used in testing to achieve the advertised DP rating.

Installation Recommendations

- ASTM E2112-07 provides basic principles to install Window, Door, and Skylight
- Reference to AAMA
- Who's code is it?
- What is the code for installation of window?
- Home Rule Doctrine (most stringent rule applies)
- Best Practices (water management vs. waterproofing)
- Non-Integral vs. Integral Flanges as well as Brick Mold

Barrier Systems

Membrane Drainage Systems

Surface Barrier Systems

Water Management

***Where do I want my
incidentals to go?***

answer: Exterior Drainage Plane

Installation

Identify the Weather Barrier System (Surface Barrier System)

- Exterior surface is relied upon to repel the water
- Can be a solid wall or mass wall
- Does not include a secondary drainage plane
- Ties to window with a sealant joint

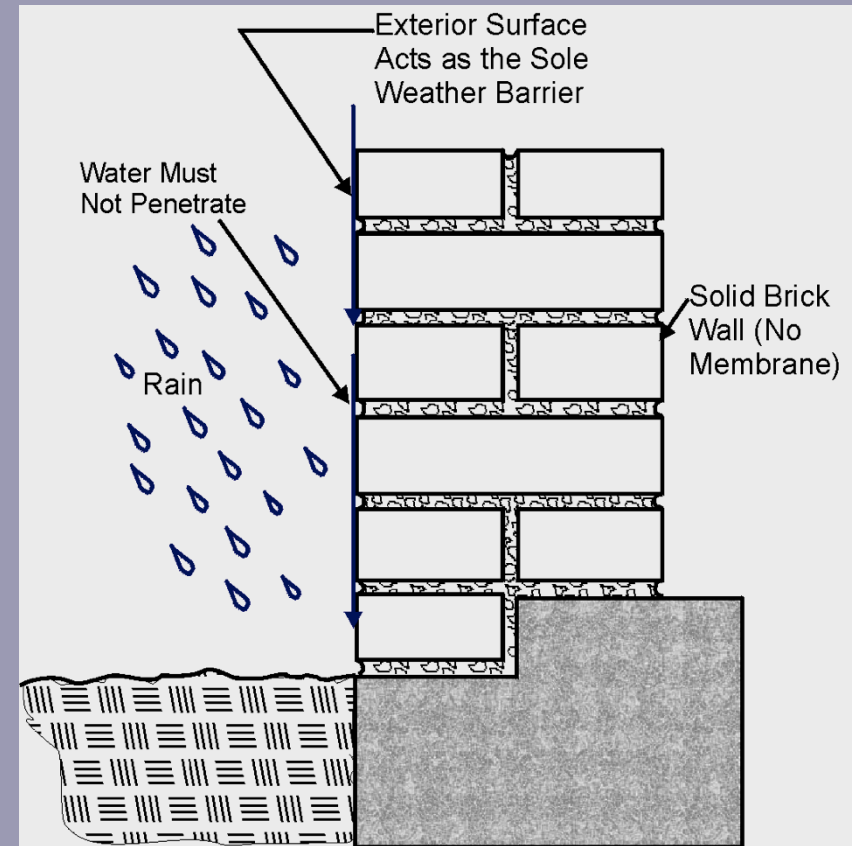

Installation

Identify the Weather Barrier System (Membrane Drainage System)

- Exterior surface repels most water, but not all
- Weather resistive barrier (WRB) is located behind the exterior surface
- Integrate windows and doors into WRB with flashing and sealant

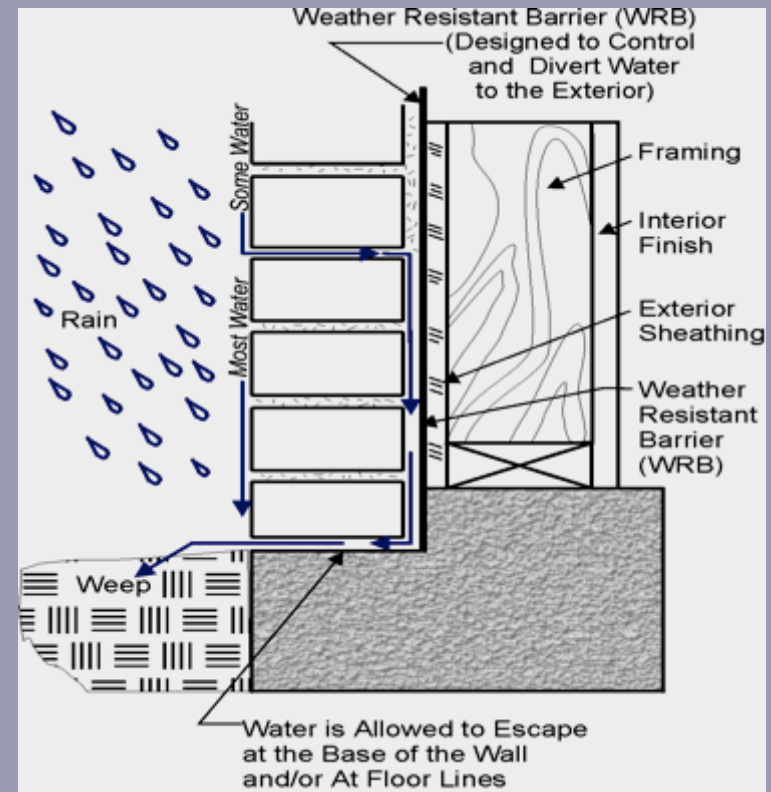

Installation

New Construction - Level, Plumb, Square, and True

Four terms important to performance and operation

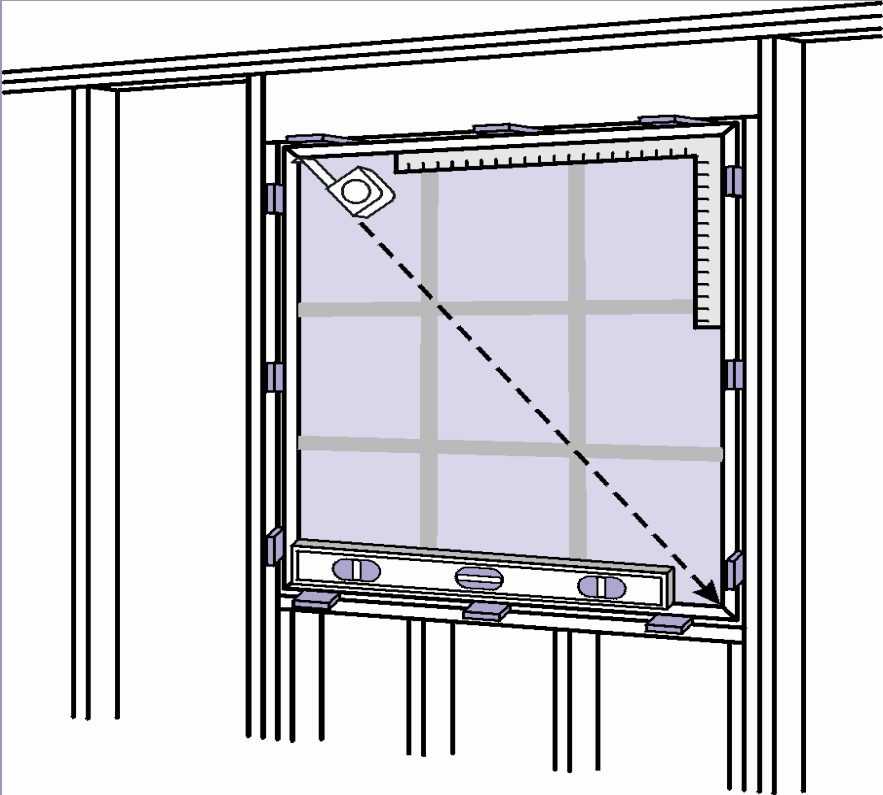

LEVEL, SQUARE, AND PLUMB

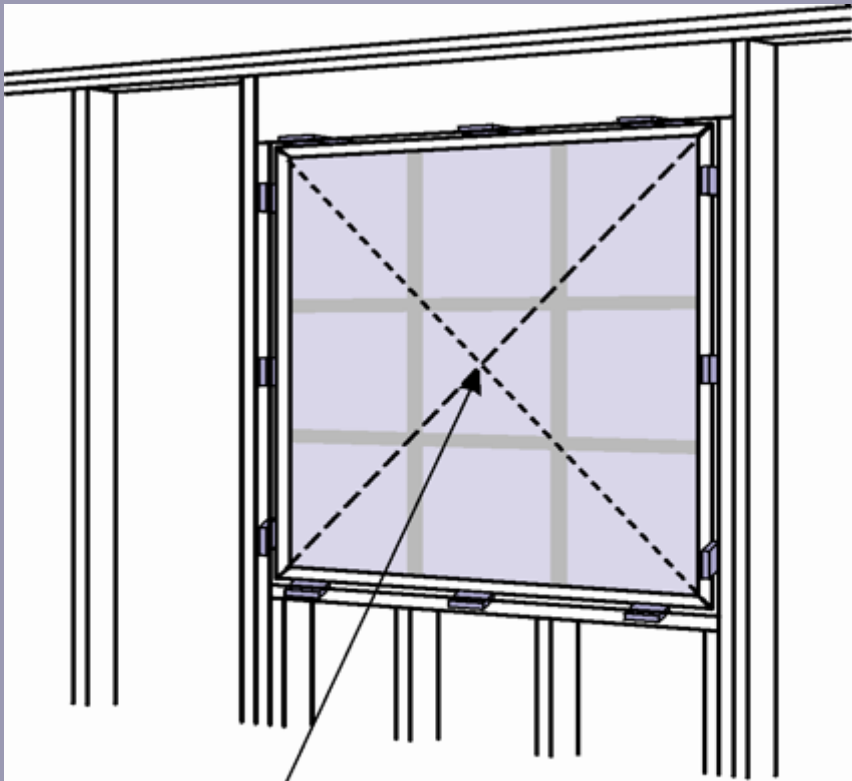

Strings Touch If "True"

TRUE

Installation

Define - Level, Plumb, Square, and True

Definitions:

Level — having no part higher than another; having a flat or even surface; being in a plane parallel to the plane of the horizon; horizontal.

Plumb – True (exact or precise) according to a plumb line (a cord with a lead bob attached to one end that is used to determine perpendicularity); perpendicular: vertical

Square - to bring to the form of a right angle or right angles; set at right angles to something else.

How to Measure:

Level — sometimes called a 'spirit level'. To determine if a floor, shelf, countertop or other flat surface is level you will need a level. I recommend a 2 ft. level for most projects because it is the most versatile. If you have a very long surface you will get more accurate results with a longer level. To use a level place it onto the surface you want to measure. Be sure that surface is smooth without bumps or debris. Look at the liquid filled, glass tube in the center of the level and make adjustments up or down until the bubble is sitting between the 2 black lines.

Plumb — To determine if a vertical surface like a wall, fence post or pole is plumb you can use your level for this job, too. Place the level up against the surface you are check for plumb being sure the surface is smooth and free of debris. For this measurement you will use the liquid filled tube on one end of your level. Make adjustments until the bubble is in between the 2 black lines.

Square — To determine if the place at which 2 surfaces meet are 90° apart you will need either a speed square or a framing square. When you place either of these tools at the point at which 2 surfaces the sides of the tool should sit flat on both surfaces. If there is a gap on one side or the other you will need to make the necessary adjustments.

Author: Judy Browne

Installation

Opening and Framing Requirements

Rough openings (RO)

1" wider and 1/2" higher than the outside measurement of frame

Masonry openings (MO)

A minimum of 1/2" wider and 1/4" higher than the outside measurement of frame

Rigid sill pans will decrease the RO height clearance.

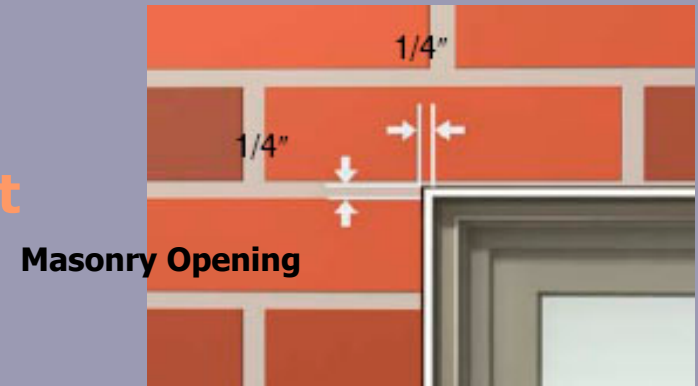
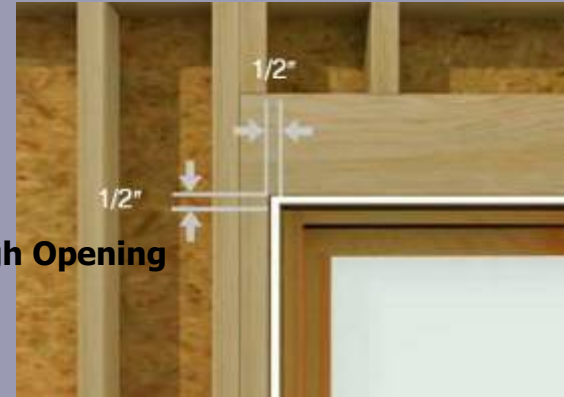

Brick Bind

Rough Opening Preparation

Standard wood frame construction with brick veneer - 1/2" min. between the bottom of the window sill and top row of brick to avoid "brick bind."

Additional clearance may be advisable on multiple story buildings.

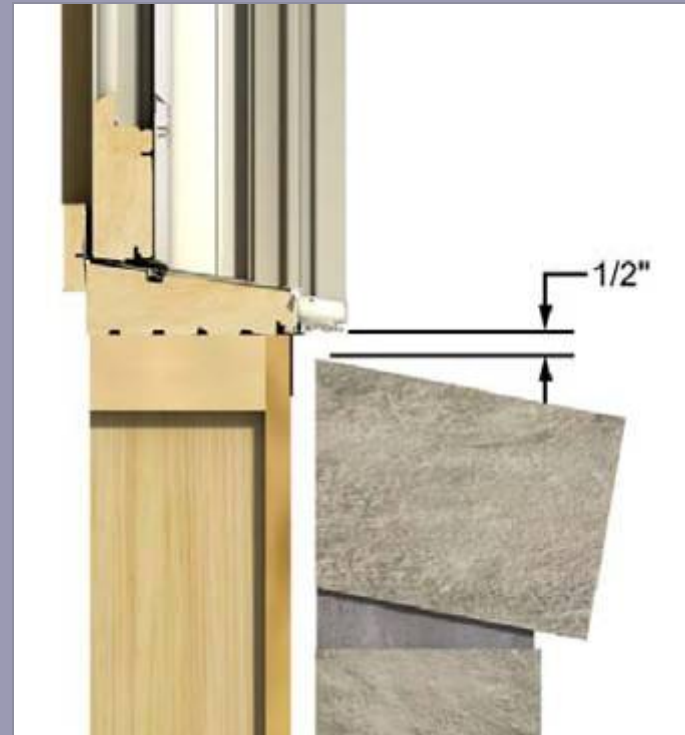

Clearance Provisions

- Unless otherwise specified, provide at least 1/2" at the top and 1/2" clearance on each side.
- Also note the thickness of Sill Pan.

Clearance Provisions

- Unless otherwise specified, provide at least 1/2" at the top and 1/4" clearance on each side.
- Also note the thickness of Sill Pan.

Proper Shimming

- Within 4” from corners and in intervals of 15” and as directed by Manufacturer.
- Contact points - Corners, checkrails, meeting stiles, lock points and hinge points.
- The purpose of shimming is to keep your window frame within 1/16” of straight.

Positioning Window: center it in the opening, level at the sill, and plumb the frame to desired depth. If necessary, shim under the jambs to bring to level.

Wedge Shims: typically made of wood, easy to apply, used in pairs, restricted to top and side applications.

Rectangular Shims, Horseshoe Shims and Shim Packs: generally made of high impact plastic, can be used in most types of application

Shimming

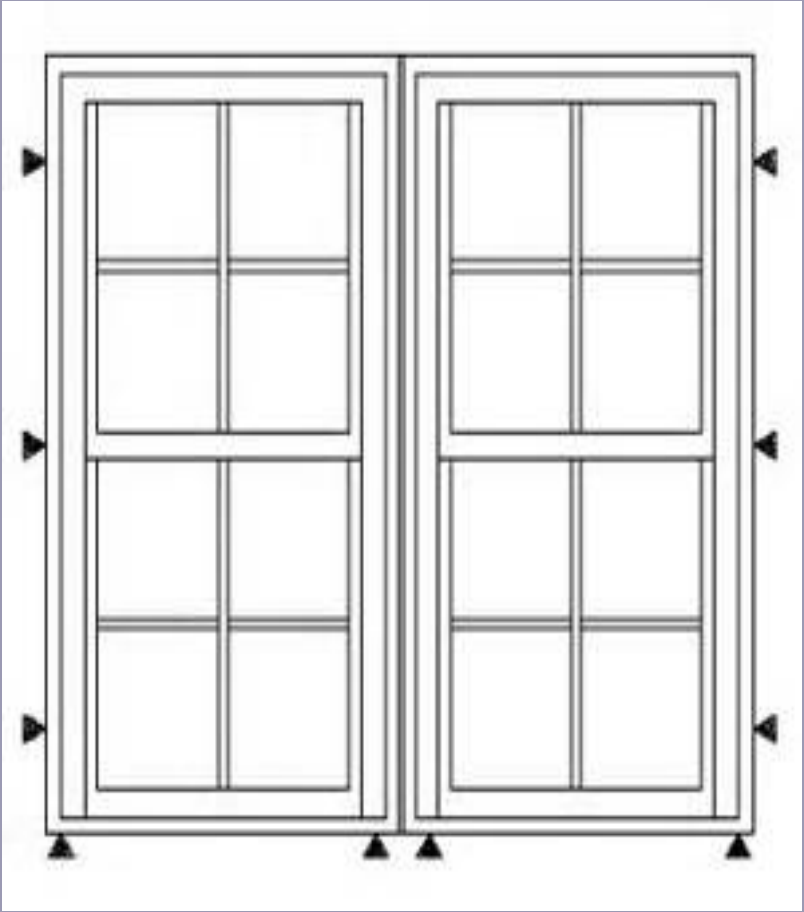
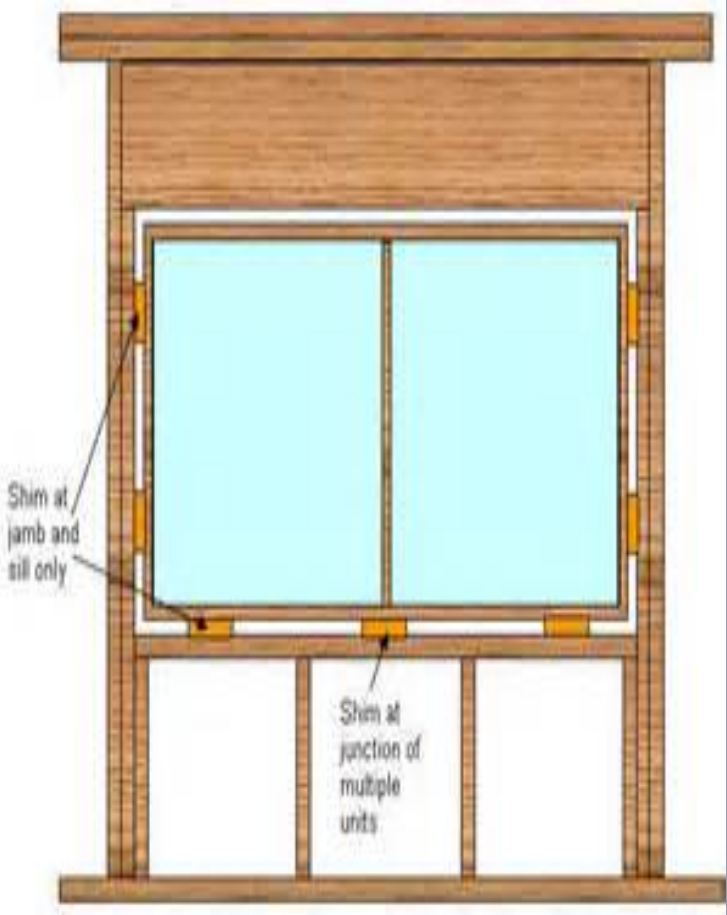

Installation

Clad Window Installation

Standard Wood Frame Construction

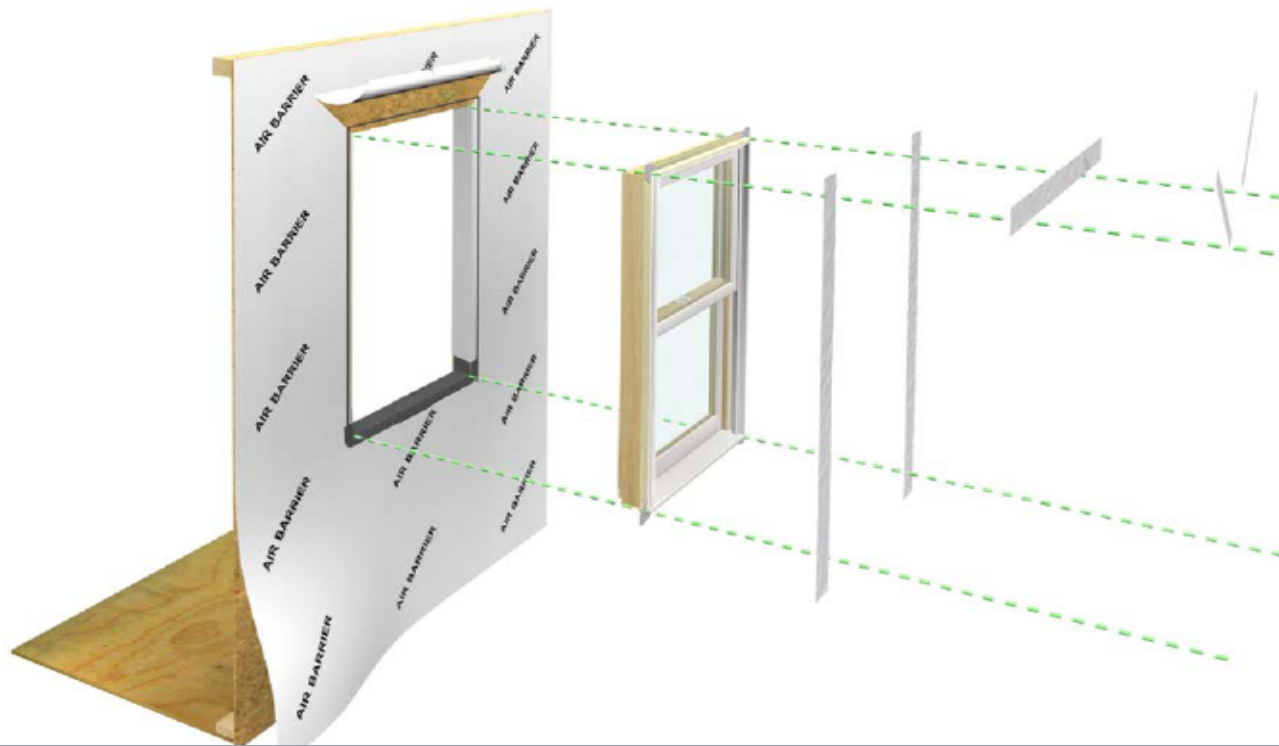

Installation

Step 5: Flashing the Installation

Air Barrier Applications

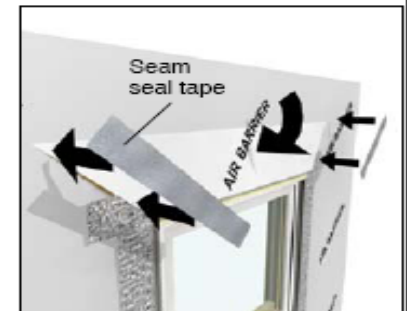
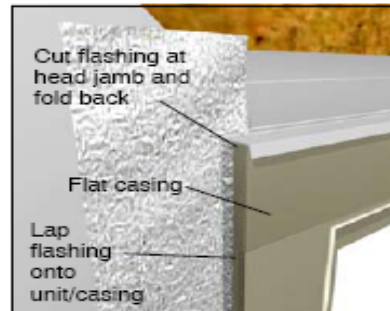
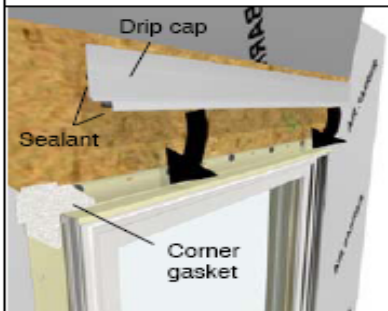

(a)



(b)

Install flashing at head jamb to cover drip cap and membrane at jamba

Install flashing to cover wrap and lap onto window jamb/casing

Fold air barrier down over membrane



(c)

Installation

Technical Installation Specifications

The following details are specified for proper installation and for the unit to meet the advertised design pressure (DP) rating.

- Rough Opening Width: 1/4"-1" (6-25) wider than window/door frame outside measurement.
- Rough Opening Height: 1/4"-1/2" (6-13) higher than window/door frame outside measurement.
- Masonry Opening Width: 1/4"-1/2" (6-13) wider than window/door frame outside measurement.
- Masonry Opening Height: 1/8"-1/4" (3-6) higher than window/door frame outside measurement.

Architectural Detail Manual Specifications:

- Rough Opening: Width 1" (25); Height 1/2" (13).
- Masonry Opening: Width 1/2" (13); Height 1/4" (6).
- A rigid, sloped sill pan integrated with the weather resistive barrier. The panning must drain water to the exterior of the cladding OR the exterior surface of a concealed weather resistive barrier.

- Properly flash and/or seal all windows at the exterior perimeter.
- Sealants used for installation must be Grade NS Class 25 per ASTM C920 and compatible with the building exterior, window exterior surface, and flashing/water management materials.
- The following materials were used to develop these instructions:

Weather Resistant Barriers: DuPont™ Tyvek® HomeWrap or Grade D building paper.

Flashing Materials: DuPont™ FlexWrap or DuPont™ Straight Flash, DuPont™ Tyvek® Tape.

Sealant: OSI® Quad Pro-Series®; solvent release butyl rubber sealant or DAP DynaFlex230™.

Panning System: Marvin SillGuard™.

Other materials may be used but must be

- Flashing materials must comply with ASTM E2112-01, section 5.13 and be compatible with all materials used in installation including panning systems, air barriers and building papers, sheathing, and the window unit.
Flashing material must not contain asphalt and must be compatible with flexible PVC (vinyl).

2: (51) galvanized roofing nails spaced no more than 4" (102) from each corner and spaced no more than 8" (203) on center around the entire perimeter.

bility

e low
comply

ickets,

d head
er and
ls and

aterial.
ust be
zed or

ct with

Sill Pan Flash

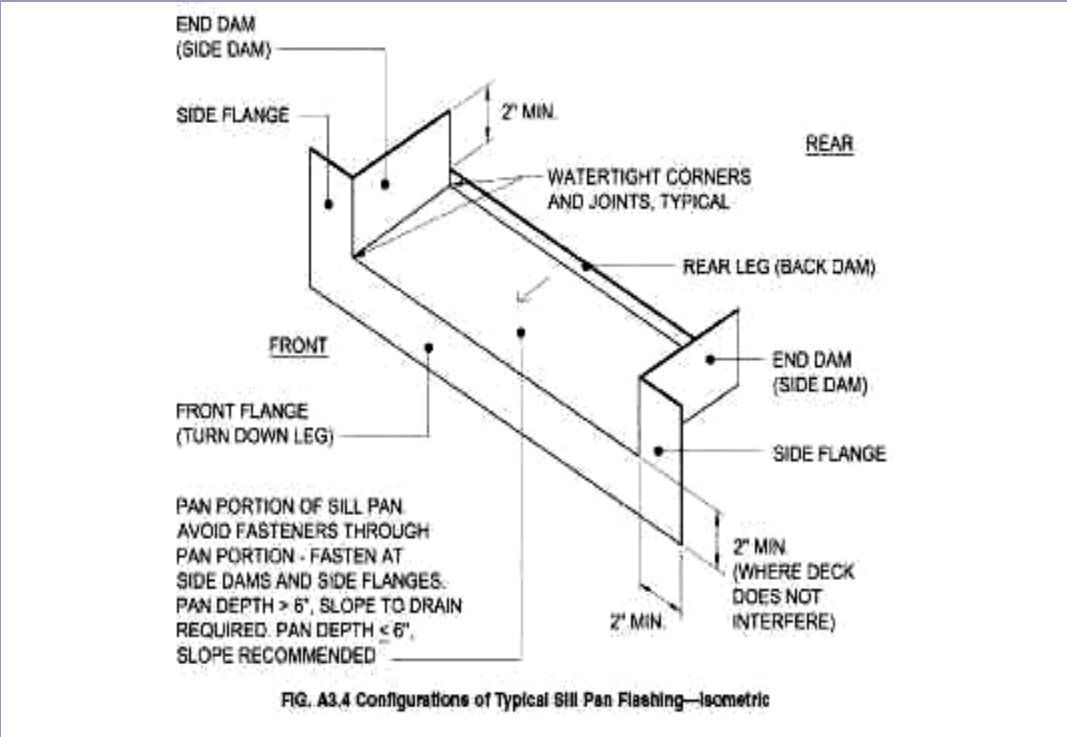

Installation

Sill Pan Flash Types

Rigid Sheet	1 piece or multiple pieces	Type I
Rigid Sheet	Multiple pieces	Type II
Flexible Membrane	1 piece or multiple pieces	Type III
Combination Systems	Multiple pieces	Type IV
Liquid Membrane	Continuous coating	Type V

(Based on and expanded from ASTM E2112-07, Table 5.)

Installation

Types of Sill Pan Flash

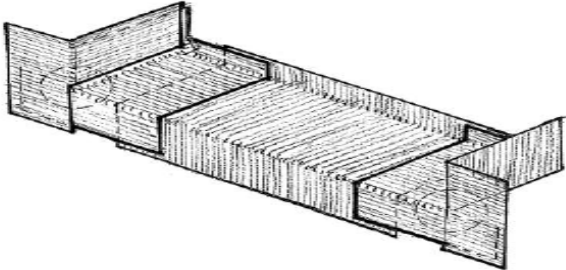
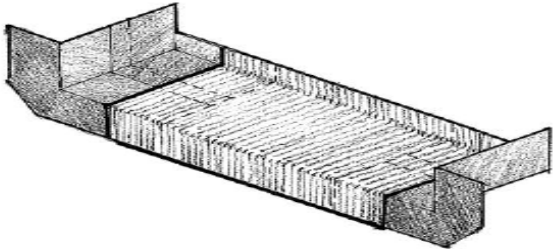
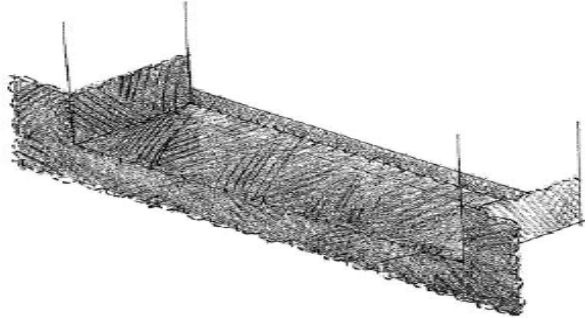
Type	Material	Fabrication	Diagram
Type III	Flexible membrane – self-adhering flashing	Multiple pieces, membrane pieces lapped watertight	
Type IV	Combination – rigid + membrane flashing	Multiple pieces – usually formed rigid comers joined with lapped self-adhering membrane sheet(s)	
Type V	Liquid – membrane coating	1-piece: spray-, brush-, or roller-applied coating applied directly to the substrate. Note: integrate with any separate flashing & WRB	

Installation

Types of Sill Pan Flash

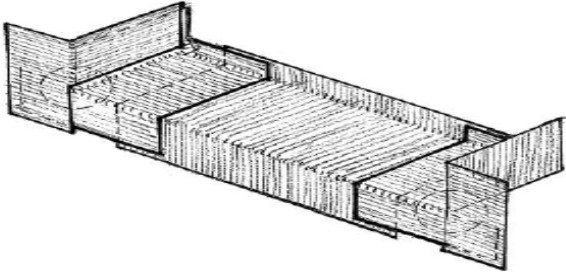
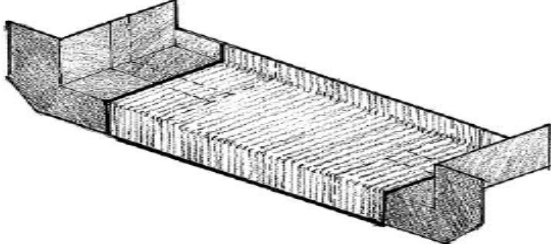
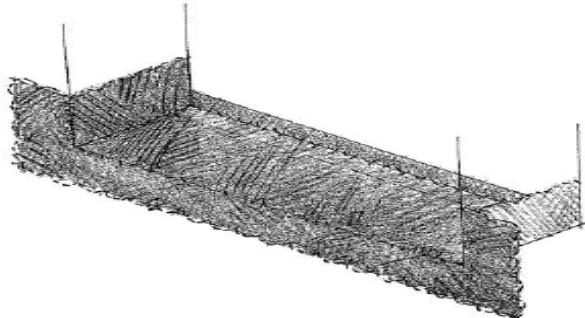
Type	Material	Fabrication	Diagram
Type III	Flexible membrane – self-adhering flashing	Multiple pieces, membrane pieces lapped watertight	
Type IV	Combination – rigid + membrane flashing	Multiple pieces – usually formed rigid comers joined with lapped self-adhering membrane sheet(s)	
Type V	Liquid – membrane coating	1-piece: spray-, brush-, or roller-applied coating applied directly to the substrate. Note: integrate with any separate flashing & WRB	

Installation

Sealants

ASTM C920 Sealant Schedule

- Silicone, Latex, Polyurethane, Butyl, Acrylics, Synthetics

Grade NS

- Non-sagging product

Class 25

- 25 % Elongation (the ability to move 15-40%)

Seek proper choices

- Compatibility with other substrates in window interface to the wall (building materials, flashings, sealants, dissimilar materials, fasteners and Etc.)
- **KNOW YOUR S_____ (Substrates)**

Sealants

- **Compatibility** - Watch for:
 - Hardening or softening
 - Tackiness (after normal cure time)
 - Loss of adhesion
 - Discoloration or bleeding
- **Surface Preparation**
 - Sound - free of rotted wood, loose paint, mortar or concrete, etc.
 - Clean - free of dirt, dust, oily substances, and/or old sealant
 - Dry and free of frost

Product Compatibility or Incompatibility ??

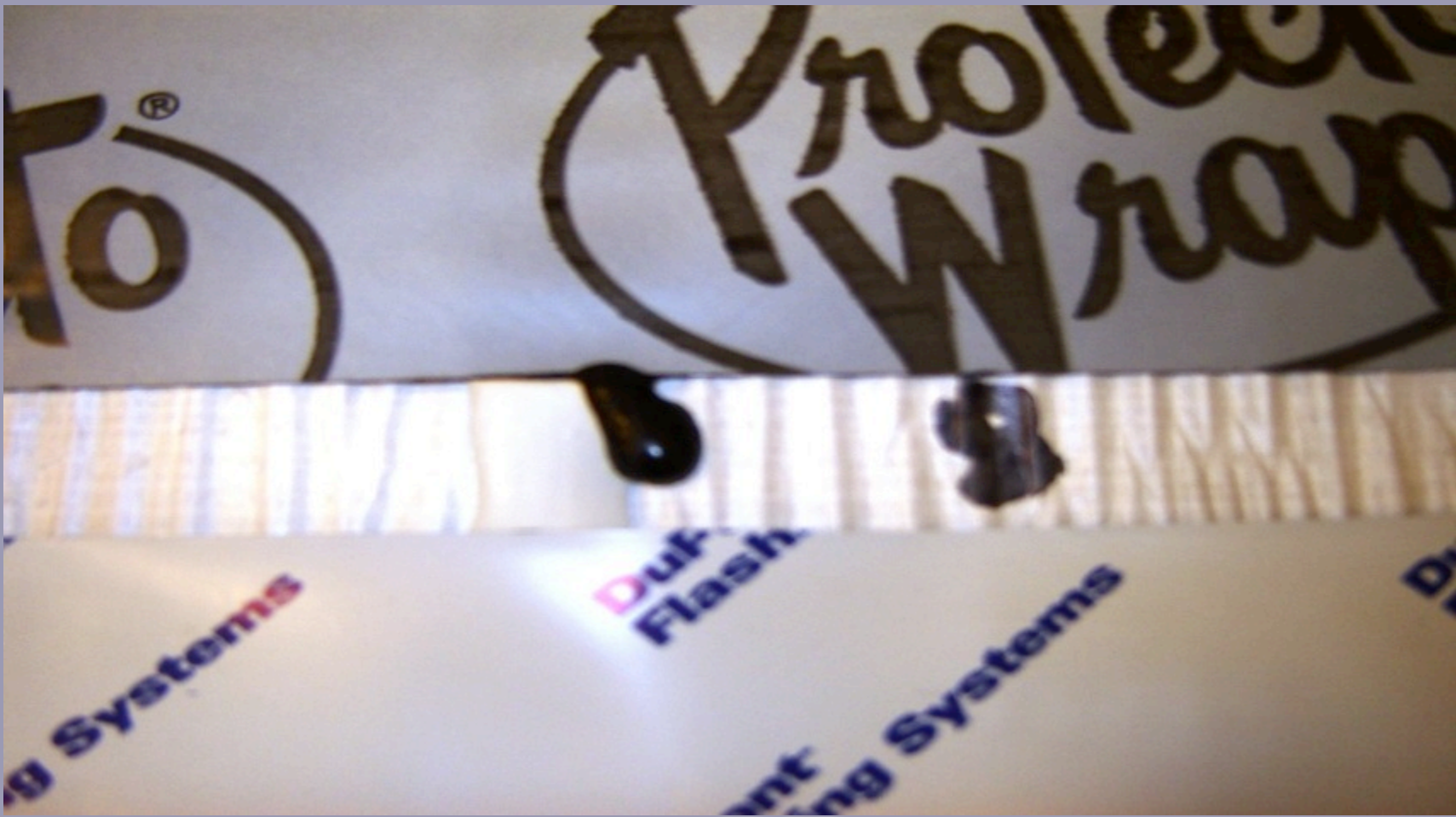

Installation

Sealant Adhesion and Application Matrix

ADHESION							APPLICATION						
SEALANT ADHESION GUIDE	SILICONE	POLYURETHANE	LATEX (MEETING ASTM C920)	LATEX	SOLVENT RELEASED	BUTYL TAPE	SEALANT APPLICATION GUIDE	SILICONE	POLYURETHANE	LATEX (MEETING ASTM C920)	LATEX	SOLVENT RELEASED	BUTYL TAPE
	ALUMINUM ANODIZED	Yes	Yes	Yes	Some	Yes		Yes	BEHIND MOUNTING FLANGE ²	Yes	Yes	Some	Some
ALUMINUM MILL FINISH	Yes	Yes	Yes	Some	Yes	Yes	BOX FRAME TO OPENING	Yes	Yes	Yes	NR	Some	NR
ASPHALT BUILDING PAPER	Yes	Yes	Yes	Yes	NR	Yes	EXTERIOR CASING	Yes	Yes	Yes	Some	Some	NR
BRICK	Yes	Yes	Yes	Some	Yes	NR	EXTERIOR/INTERIOR STOP	Yes	Yes	Yes	Yes	Yes	NR
CONCRETE	Yes	Yes	Yes	Some	Some	No	EXTERIOR PERIMETER ¹	Yes	Yes	Yes	Some	Some	NR
COPPER	Yes ¹	Yes	Some	Some	Yes	Yes	HEADER EXPANDER	Yes	Yes	Yes	Some	Some	NR
EIFS	Yes	Yes	Some	NR	NR	NR	INTERIOR TRIM AND STOOL	NR	Yes	Yes	Yes	NR	NR
FIBERGLASS	Yes	Yes	Some	Some	Some	Yes	MULL SEAL	Yes	Yes	Some	NR	NR	NR
GALVANIZED STEEL	Yes ¹	Some	Some	Some	Yes	Yes	PANNING	Yes	Yes	Yes	NR	Some	NR
GLASS	Yes	Some	Yes	Some	Yes	Yes	SILL ANGLE	Yes	Some	Yes	NR	Some	NR
HOUSE WRAP	Some	Some	Some	Some	Some	Yes	SILL CAPPING	Yes	Some	Yes	NR	Some	NR
PAINTED SURFACES ²	Yes	Yes	Yes	Yes	Yes ³	Yes	SILL EXTENDER	Yes	Yes	Yes	Some	Some	NR
POLYETHYLENE	Some	Yes	No	No	Yes	Yes	THRESHOLD	Yes	Yes	Some	NR	Some	NR
POLYSTYRENE FOAM BOARD	Yes	Yes	Yes	Some	NR	Yes	UNDER DOOR SILL PAN	Yes	Yes	Some	NR	Some	NR
STUCCO	Yes	Yes	Yes	Some	Some	NR	UNDER FLASHING ²	Yes	Yes	Some	Some	Some	Yes
VINYL	Some ¹	Some	Some	Some	Some	Some	WALL STOOL	Yes	Yes	Yes	Some	Some	NR
WOOD	Yes	Yes	Yes	Yes	Yes	Yes							

¹ = Neutral Cure Silicone Only	¹ = Match Sealant Movement Capability to Anticipated Joint Movement
² = Check Paint Individually	² = Check Adhesion and Compability to Mating Surfaces
³ = Check for Compatibility	NR = Not Recommended
NR = Not Recommended	Some = Many Are Not Adequate
SOME = Many Are Not Adequate	Yes = Majority Are Adequate
YES = Majority Are Adequate	

Installation

Points to know and understand about BUTT Joints

Two Sided adhesion

C - Clean

P - Prime

P - Pack

S - Shoot

T - Tool

Note ! Backer Rod controls depth of joint and helps with adhesion and movement

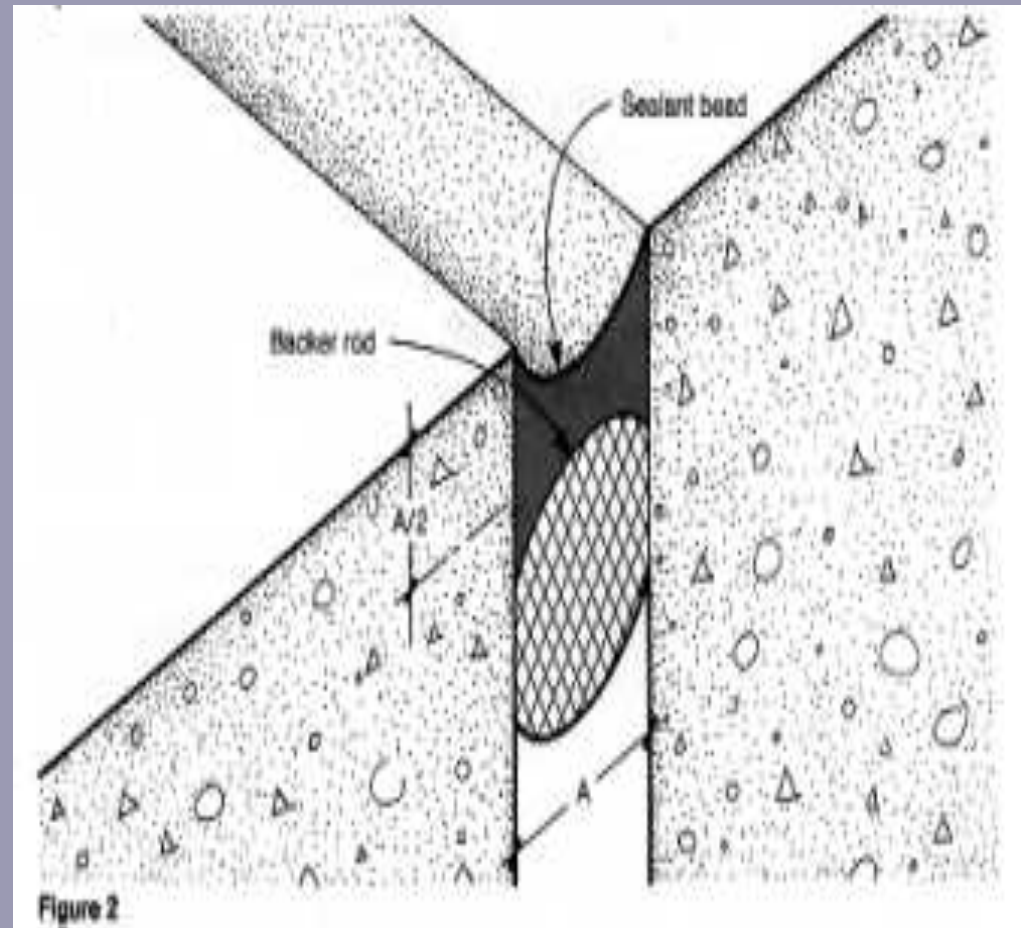

Installation

Joint and Sealant Dimensions

- At least 1/4" sealant bond to each contact surface
- Butt joints of Porous surfaces (concrete, masonry, or brick)– For 1/4" to 1/2" width, the width should equal the depth

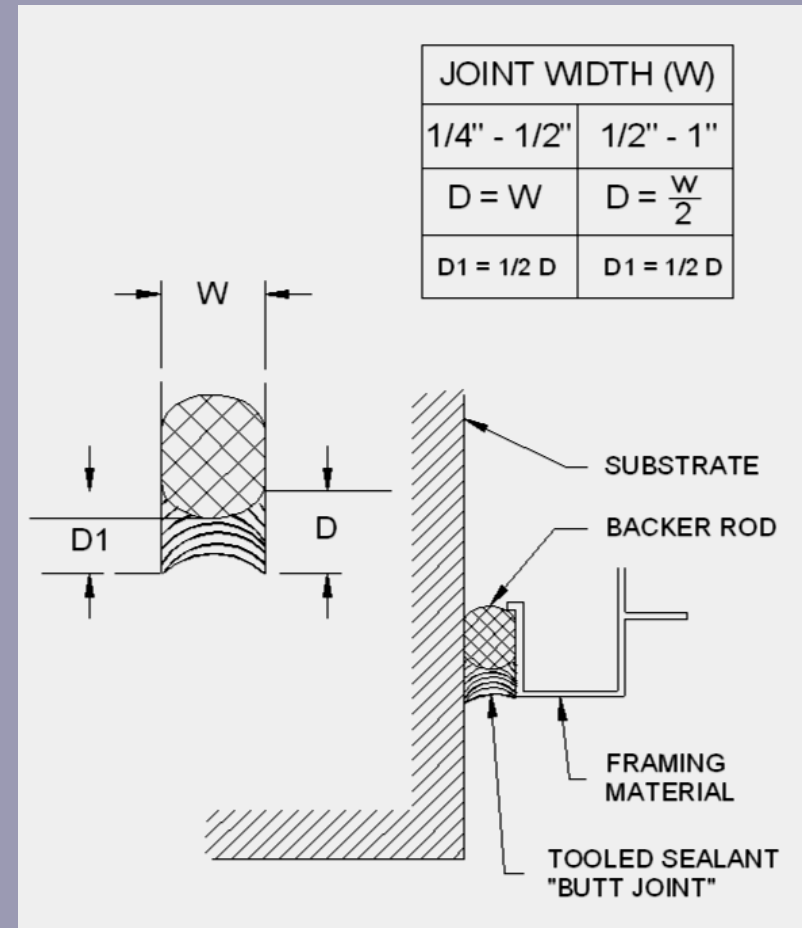

Installation

Sealant Joints

- Three sided adhesion of the sealant may result in both adhesive and cohesive failures

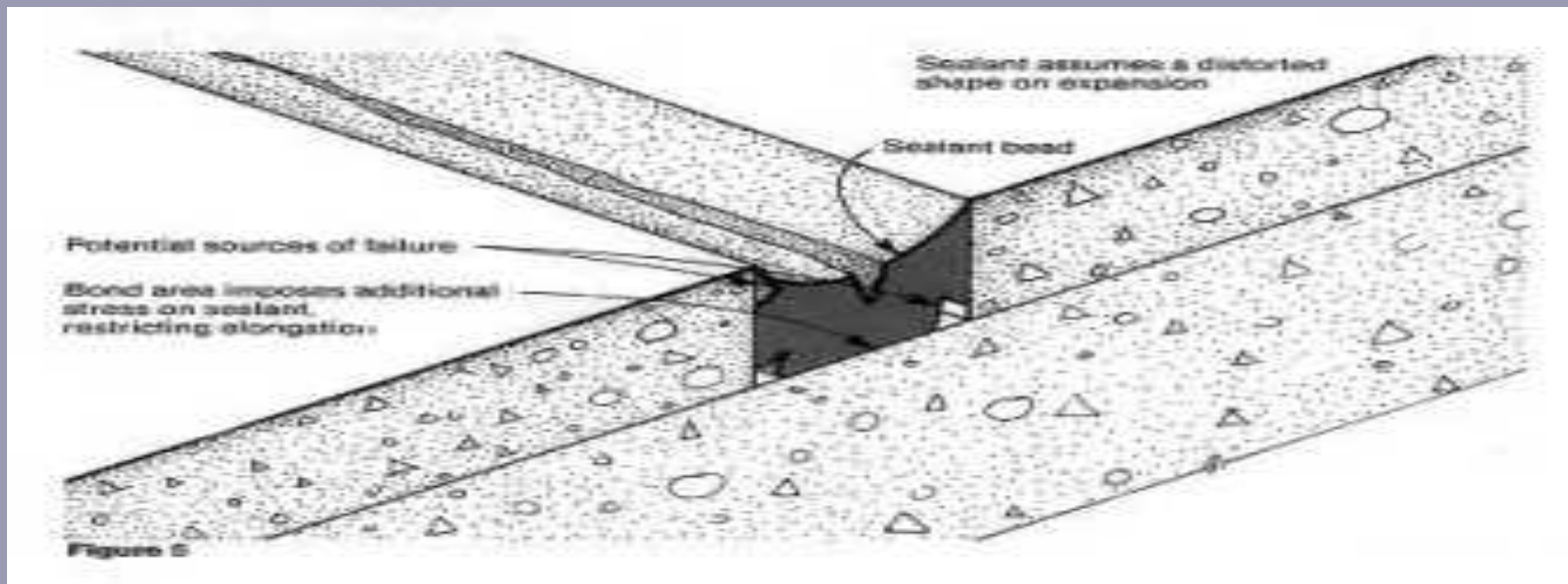

Installation

ADM Flashing Details

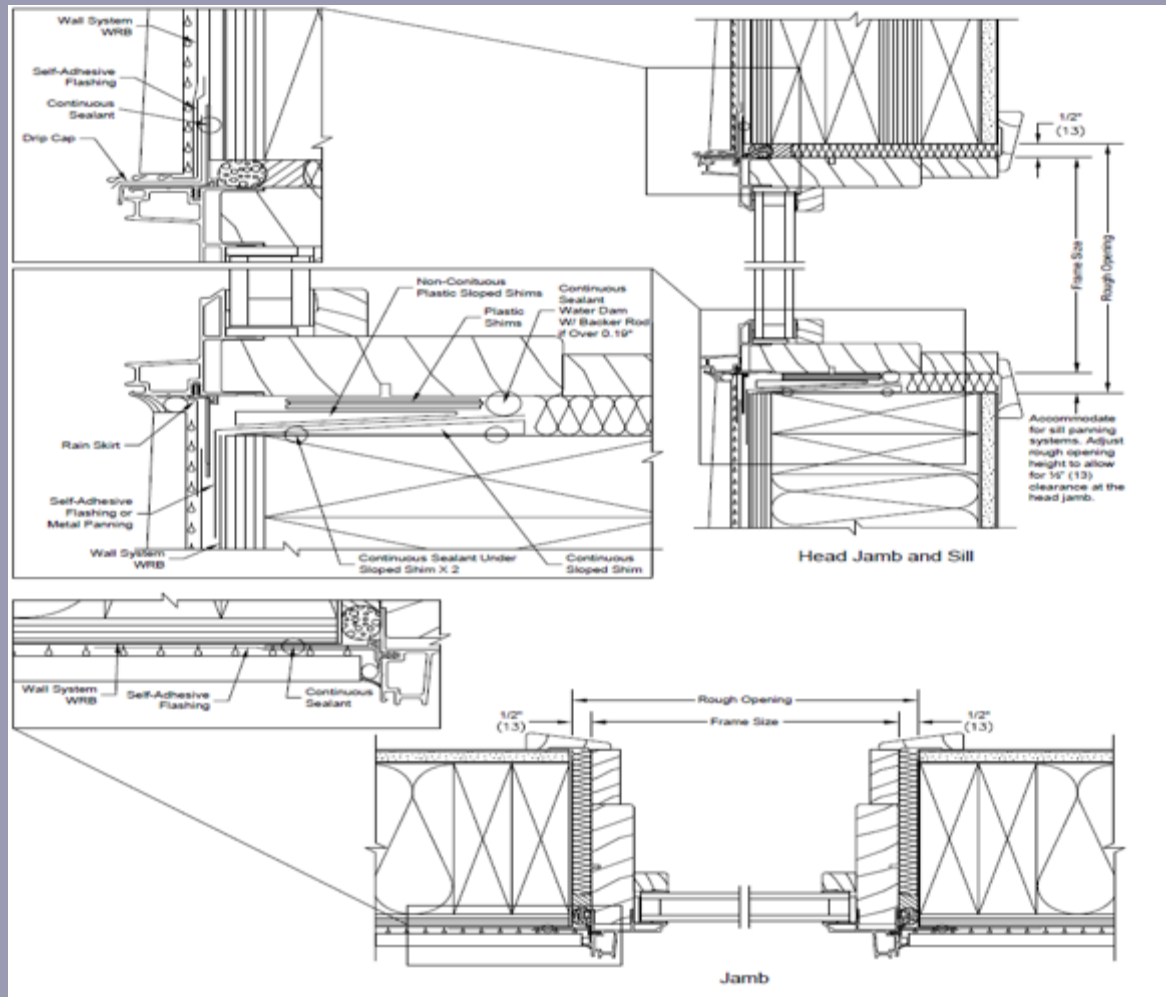

Installation

Sealant Joints

**THOUGH A SMALL PART OF A BUILDING'S EXTERIOR,
SEALANTS PERFORM A VERY LARGE FUNCTION**

Joints sealed with an elastomeric sealant usually fail from a combination of factors that can be summed up in six words -

The lack of attention to detail

Too often, since the sealants are a small percentage of the work, they are perfunctorily specified, easily substituted, and haphazardly applied. Yet successful joints require meticulous design, precise sealant selection, and painstaking application.

Weather Board Flashing

All wraps and flashings are installed in a weather-board fashion.

This allows the building to shed any water that may reach the building wrap.

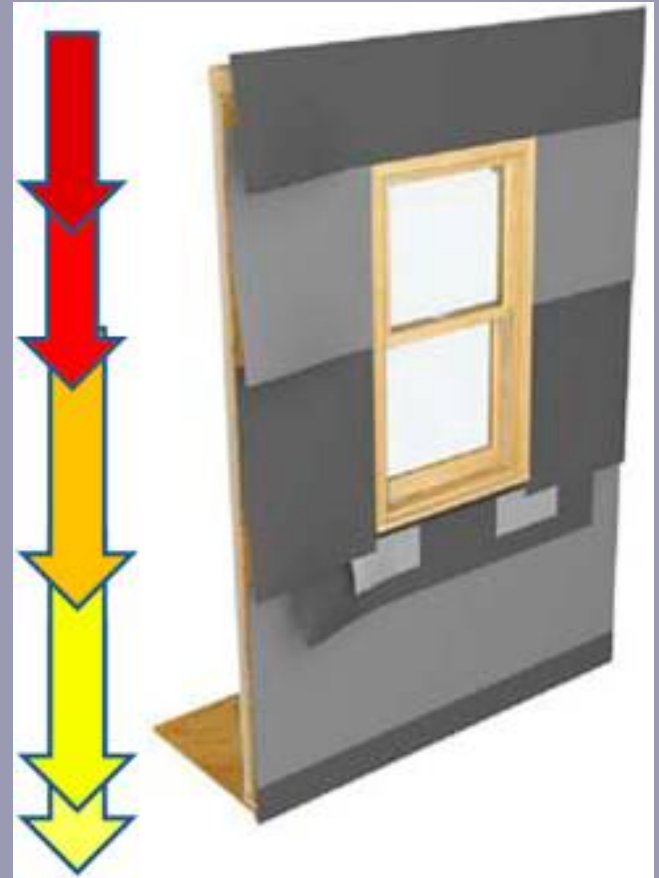

Mounting Flange Installation Methods

- Method A
- Method B
- Method A-1
- Method B-1

DETERMINING THE PROPER LENGTH OF FLASHING	
SILL FLASHING	= RO ^w + (2 x FLASHING WIDTH)
JAMB FLASHING	= RO ^h + (2 x FLASHING WIDTH) - 1"
HEAD FLASHING	= RO ^w + (2 x FLASHING WIDTH) + 2"
LEGEND	
RO = ROUGH OPENING RO^h = ROUGH OPENING VERTICAL HEIGHT RO^w = ROUGH OPENING HORIZONTAL WIDTH	

Flashing Method Selection Chart			
(Based on doors with integral fins being installed in membrane/drainage type wall systems)			
		A	B
		Jamb flashing will be applied AFTER the door or OVER the face of the mounting flange	Jamb flashing will be applied BEFORE the door or BEHIND the face of the mounting flange
	Weather resistant barrier (WRB) is to be applied AFTER the door installation	Use Method "A"	Use Method "B"
I	Weather resistant barrier (WRB) is to be applied FIRST or BEFORE the door installation	Use Method "A1"	Use Method "B1"

Installation

Sill Panning Systems: Beveled Cedar Sill (R.O. Prep)

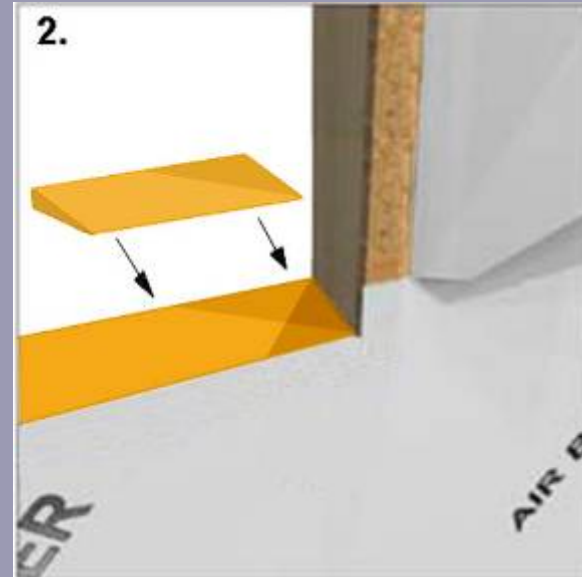
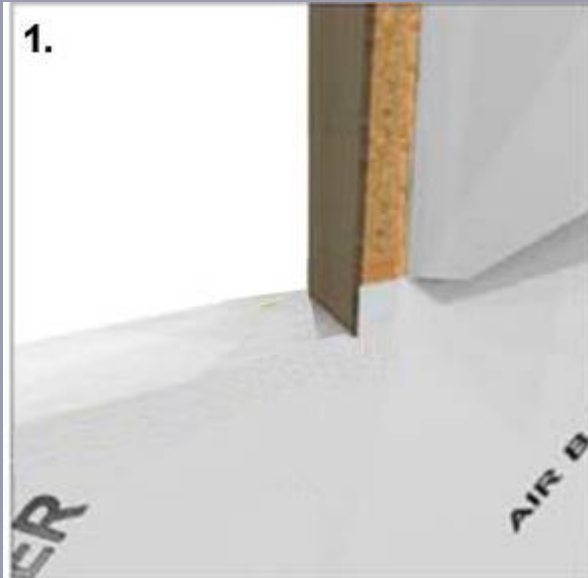

Installation

Sill Panning Systems: Beveled Cedar Sill

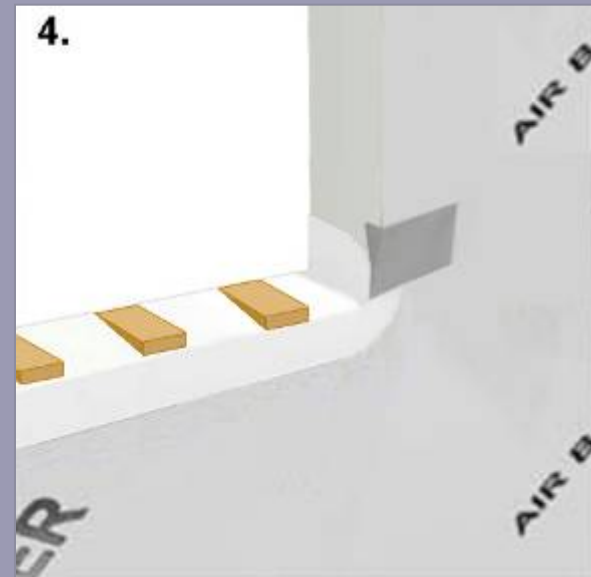
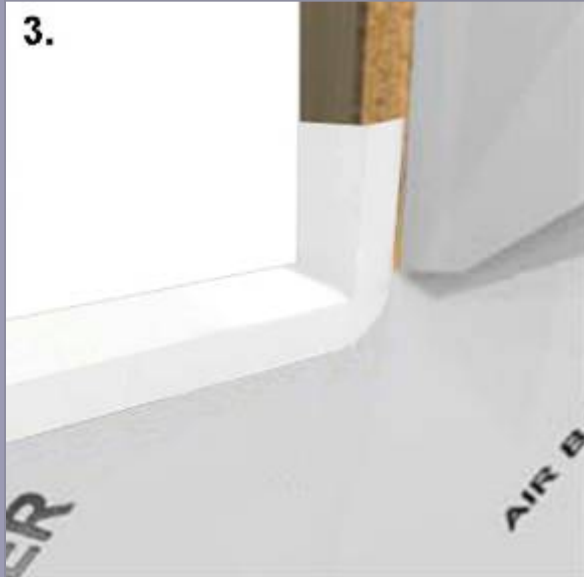

Installation

High Pressure Skirt

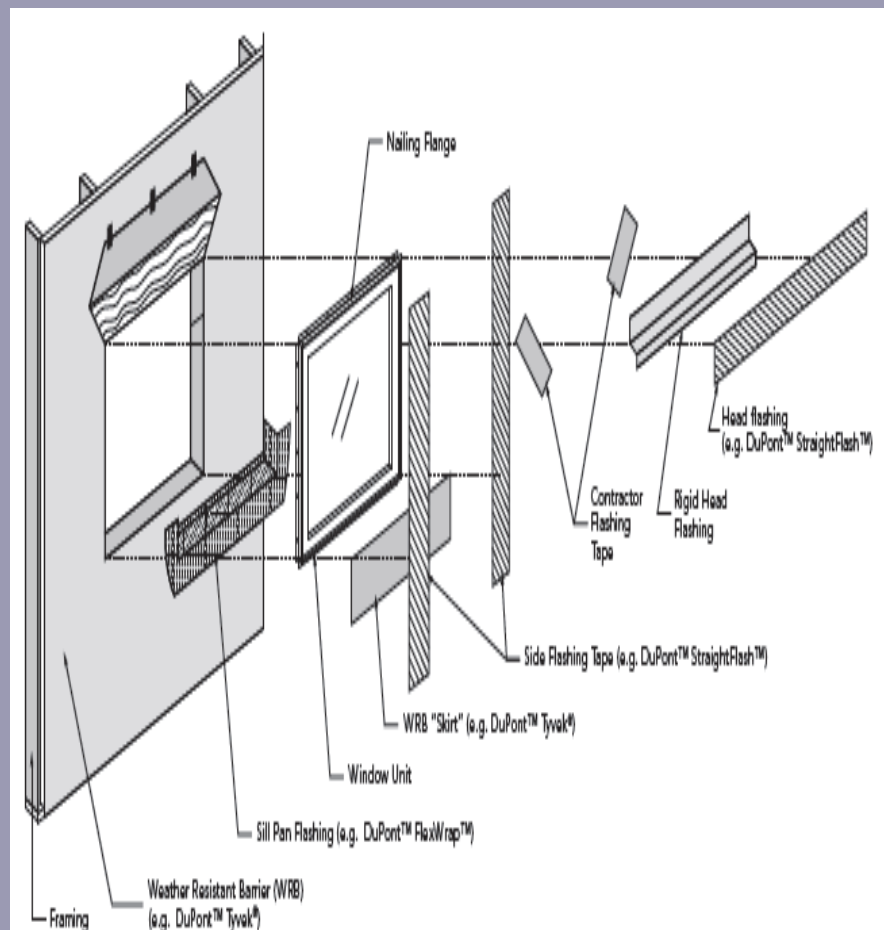
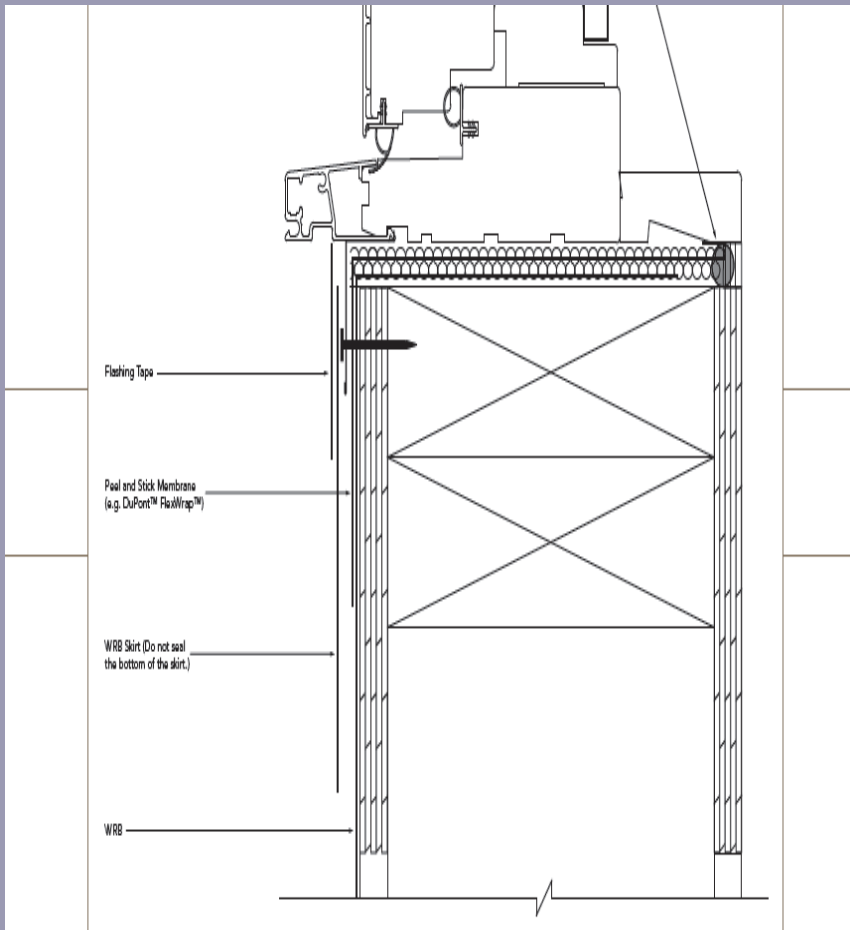

Installation

Questions

Items mentioned & used in today's presentation

- **Utility Knife**
- **Level**
- **Hammer Tacker**
- **Laser Level**
- **Speed Square**
- **Tape Measure**
- **Flashing Tape**
- **Type III Sill Pan Flash**
- **Sealant**
- **Sheathing Tape**
- **Beveled piece of Cedar Siding**
- **Shims**
- **Corner Gaskets**
- **High Pressure Skirt**
- **Tyvek House Wrap**
- **High Pressure Skirt**

Questions

***Thank you for your time and attention to this course.
It has been a pleasure to work with you today.***

Eric Klein
Marvin Windows and Doors
Installation and Field Service Instructor
Warroad, MN 56763

erickl@marvin.com



Installation